

up-to-date electronics for lab and leisure

ELEKTOR 23

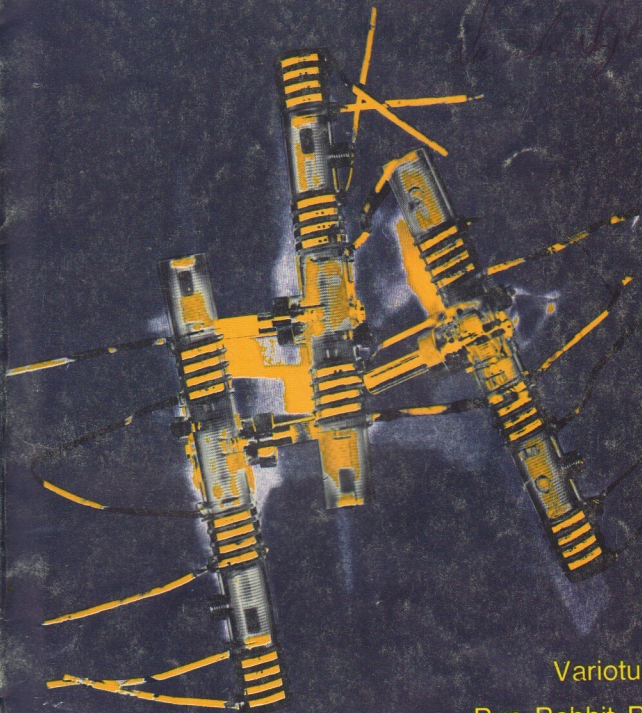

Variotuner

Run, Rabbit, Run!

Morse decoder with DDLL

March 1977 45 p / USA \$ 1.50

ELEKTOR

decoder

Editor : W. van der Horst

Deputy editor : P. Holmes

Technical editors : J. Barendrecht
G.H.K. Dam
E. Krempelsauer
G.H. Nachbar
Fr. Scheel
K.S.M. Walraven

Art editor : C. Sinke

Subscriptions : Mrs. A. van Meyel

UK editorial offices, administration and advertising:
6 Stour Street, Canterbury, CT1 2XZ.
Tel. Canterbury (0227) - 54430. Telex: 965504.
Bank: Midland Bank Ltd Canterbury A/C no. 11014587,
Sorting code 40-16-11, giro no. 3154254

Assistant Manager and Advertising : R.G. Knapp
Editorial : T. Emmens

Elektor is published monthly on the third Friday of each month, price 45 pence.
Please note that number 27/28 (July/August) is a double issue, 'Summer Circuits', price 90 pence.
Single copies (including back issues) are available by post from our Canterbury office to UK addresses and to all countries by surface mail at £ 0.60
Single copies by air mail to all countries are £ 0.95
Subscriptions for 1977 (January to December inclusive): to UK addresses and to all countries by surface mail: £ 6.25, to all countries by air mail £ 11.-.
Subscriptions for 1977 (April to December inclusive):
To U.K. addresses and to all countries by surface mail: £ 4.70.
All prices include p & p.

Change of address. Please allow at least six weeks for change of address. Include your old address, enclosing, if possible, an address label from a recent issue.

Letters should be addressed to the department concerned:
TQ = Technical Queries, ADV = Advertisements, SUB = Subscriptions, ADM = Administration, ED = Editorial (articles submitted for publication etc.); EPS = Elektor printed circuit board service.
For technical queries, please enclose a stamped, addressed envelope.

The circuits published are for domestic use only. The submission of designs or articles to Elektor implies permission to the publishers to alter and translate the text and design, and to use the contents in other Elektor publications and activities. The publishers cannot guarantee to return any material submitted to them. All drawing, photographs, printed circuit boards and articles published in Elektor are copyright and may not be reproduced or imitated in whole or part without prior written permission of the publishers.

Patent protection may exist in respect of circuits, devices, components etc. described in this magazine.
The publishers do not accept responsibility for failing to identify such patent or other protection.

National advertising rates for the English edition of Elektor and/or international advertising rates for advertising at the same time in the English, Dutch and German issues are available on request.

Distribution: Spotlight Magazine Distributors Ltd,
Spotlight House 1, Bentwell Road, Holloway, London N7 7AX.

Copyright © 1977 Elektor publishers Ltd — Canterbury.

Printed in the Netherlands.

What is a TUN?
What is 10 n?
What is the EPS service?
What is the TQ service?
What is a missing link?

Semiconductor types

Very often, a large number of equivalent semiconductors exist with different type numbers. For this reason, 'abbreviated' type numbers are used in Elektor wherever possible:

- '741' stands for μ A741, LM741, MC741, MIC741, RM741, SN72741, etc.
- 'TUP' or 'TUN' (Transistor, Universal, PNP or NPN respectively) stands for any low frequency silicon transistor that meets the specifications listed in Table 1. Some examples are listed below.
- 'DUS' or 'DUG' (Diode, Universal, Silicon or Germanium respectively) stands for any diode that meets the specifications listed in Table 2.
- 'BC107B', 'BC237B', 'BC547B' all refer to the same 'family' of almost identical better-quality silicon transistors. In general, any other member of the same family can be used instead. (See below.)

For further information, see 'TUP, TUN, DUG, DUS', Elektor 21, p. 160.

Table 1. Minimum specifications for TUP (PNP) and TUN (NPN).

V _{CEO} , max	20V
I _C , max	100 mA
f _h e, min	100
P _{tot} , max	100 mW
T _j , min	100 MHz

Some 'TUN's are: BC107, BC108 and BC109 families; 2N3856A, 2N3859, 2N3860, 2N3904, 2N3947, 2N4124. Some 'TUP's are: BC177 and BC178 families; BC179 family with the possible exception of BC159 and BC179; 2N2412, 2N3251, 2N3906, 2N4126, 2N4291.

Table 2. Minimum specifications for DUS (silicon) and DUG (germanium).

	DUS	DUG
V _R , max	25V	20V
I _F , max	100mA	35mA
I _R , max	1 μ A	100 μ A
P _{tot} , max	250mW	250mW
C _D , max	5pF	10pF

Some 'DUS's are: BA127, BA217, BA218, BA221, BA222, BA317, BA318, BA313, BA561, 1N914, 1N4148.
Some 'DUG's are: OA85, OA91, OA95, AAT16.

BC107 (-8, -9) families:

BC107 (-8, -9), BC147 (-8, -9), BC207 (-8, -9), BC237 (-8, -9), BC317 (-8, -9), BC347 (-8, -9), BC547 (-8, -9), BC171 (-2, -3), BC182 (-3, -4), BC382 (-3, -4), BC437 (-8, -9), BC414

BC177 (-8, -9) families:

BC177 (-8, -9), BC157 (-8, -9), BC204 (-5, -6), BC307 (-8, -9), BC320 (-1, -2), BC350 (-1, -2), BC557 (-8, -9), BC251 (-2, -3), BC212 (-3, -4), BC512 (-3, -4), BC261 (-2, -3), BC416.

Resistor and capacitor values

When giving component values, different points and large numbers of zeros are avoided wherever possible. The decimal point is usually replaced by one of the following international abbreviations:

p (pico-) = 10^{-12}
n (nano-) = 10^{-9}
 μ (micro-) = 10^{-6}
m (milli-) = 10^{-3}
k (kilo-) = 10^3
M (mega-) = 10^6
G (giga-) = 10^9

A few examples:
Resistance value 2k7: this is 2.7 k Ω , or 2700 Ω .
Resistance value 470: this is 470 Ω .
Capacitance value 4p7: this is 4.7 pF, or 0.000 000 000 004 7 F...
Capacitance value 10n: this is the international way of writing 10,000 pF or .01 μ F, since 1 n is 10^{-9} farads or 1000 pF.

Mains voltages

No names (power line) voltages are listed in Elektor circuits. It is assumed that our readers know what voltage is standard in their part of the world!
Readers in countries that use 60 Hz should note that Elektor circuits are designed for 50 Hz operation. This will not normally be a problem; however, in cases where the mains frequency is used for synchronisation some modification may be required.

Technical services to readers

— **EPS service.** Many Elektor articles include a lay-out for a printed circuit board. Some — but not all — of these boards are available ready-etched and predrilled.
The 'EPS print service list' in the current issue always gives a complete list of available boards.
— **Technical queries.** Members of the technical staff are available to answer technical queries (relating to articles published in Elektor) by telephone on Mondays from 14.00 to 16.30.
Letters with technical queries should be addressed to:
Dept. TQ. Please enclose a stamped, self-addressed envelope; readers outside U.K. please enclose an IRC instead of stamps.

— **Missing link.** Any important modifications to, additions to, improvements on or corrections in Elektor circuits are generally listed under the heading 'Missing Link' at the earliest opportunity.

CONTENTS

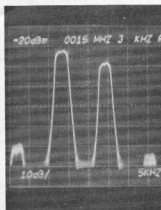

Test results of the variometer tuner are quite good. For example, inter-modulation products from two signals 10 kHz apart are typically 45 to 50 dB down.

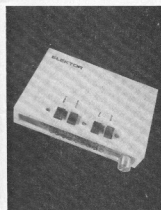

Since Run Rabbit, Run is purely electronic, the gun and an infinite supply of bunnies and bullets can be housed in a neat plastic case.

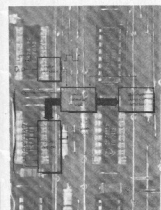

The block diagram of the morse decoder with dll looks quite simple. When it comes to the actual design (in part 2), we will be grateful for the existence of such things as printed circuit boards and ICs!



For optimum stability of tuning the variometer tuner employs permeability tuning instead of the somewhat capricious varicap. A few of these 'Variometers' can also be used to create a reasonable likeness of an artificial satellite.

selektor	3-12
ejektor	3-20
more negative feedback with positive	
highlights in the (near) future	3-21
variometer tuner (1)	3-22
This design is intended to meet the requirement for an FM tuner of outstanding performance that is easy for the home constructor to build and align. The first part of the article covers the design of the front-end and a simple i.f. strip and demodulator suitable for mono reception.	
high power inverter using gate turn-off thyristors	3-29
scope calibrator	3-30
This simple calibrator will check the gain and bandwidth of Y amplifiers and attenuators and the frequency calibration of the timebase. It is so compact that it can be built into virtually any oscilloscope, making regular calibration a simple procedure.	
elektroscope in vero-case	3-32
run rabbit, run! — A. Malchau	3-34
'Run Rabbit, Run' is a game of skill in which the object is to 'shoot' a 'rabbit'. Since both the rabbit and the gun are purely electronic this game is suitable for indoor use, with no danger of bullet-holes in the walls nor blood on the carpet.	
negative feedback — how thick to lay it on ..	3-38
Faced with misbehaviour in power amplifiers, for example, the casual designer simply lays on the 'negative feedback'. It is all so simple: feedback reduces gain and unwanted products; the extra gain needed to offset the reduction of sensitivity is easily and cheaply obtained; end of unwanted output. This article is intended for the casual designer who has already burnt his fingers trying that approach.	
running light	3-46
morse decoder with dll (1) — E.H. Leefsma	3-48
The February 1976 issue of Elektor contained a design for a decoder that would convert morse signals into alphanumeric characters. The disadvantage of this system was that the decoder had to be manually synchronised to the sending speed, which meant that it had to be individually adjusted for each incoming message and could not adapt to variable sending speeds. The new design is equipped with DLLL (Dot-Dash-Length-Logic), which automatically synchronises the decoder to the sending speed.	
market	3-52
advertisers index	3-55
missing link	3-56
IC Audio, Piano tuner, sensitive metal detector, FM on 11 meters.	

EPS**E19: NOVEMBER 1976**

reading-in-bed limiter	1660	1.35
intercom	9156*	1.05
LOGICal replacement, etc.	9192*	3.40*
albar	9428*	1.25
albar, power supply	9437*	1.15
signal horn	9438*	1.05
cricket	9468*	0.45
egg-timer-with-a- difference	9469*	0.55
capacitance (main p.c.b. and daughter board)	9516*	1.80
capacitance tap control	9707*	0.80
sensitive metal detector	9750*	1.80

E20: DECEMBER 1976

phasing and vibrato	9407*	2.75*
drill speed control	9484*	0.95
parking meter alarm	9491*	0.95
snooze-alarm-radio-clock	9500*	2.40
sirens	9751*	1.40
thermometer (2 boards)	9755*	3.55

E21: JANUARY 1977

TDA2020 audio amplifier	9144*	1.50*
hybrid IC audio amplifier	9439*	1.10*
stereo audio mixer	9444*	6.40*
noise generator	9487*	1.60
marbles	9753*	3.35

E22: FEBRUARY 1977

Elektroscope:		
timebase	9099-1*	3.—
Y preamplifier	9099-2*	3.40
low voltage power supply	9099-3*	2.65
1000 V Hi-V psu (note 1)	9099-4*	2.—
X and Y output amplifier	9099-5*	2.85
motherboard	9099-6*	3.05
2000 V Hi-V psu (note 2)	9099-7*	2.85
front panel,		
7 cm crt (note 1)	9361-1	1.85
front panel, time base	9361-2	1.40
front panel, vertical amp. (Y1)	9361-3	1.40
front panel, vertical amp. (Y2)	9361-4	1.40
front panel, 13 cm crt (note 2)	9410-1	3.80
front panel, focus, int. (note 2)	9410-2	0.85
plastic crt mask (note 2)	9410-3	2.30
note 1: needed only for 7 cm crt scope		
note 2: needed only for 13 cm crt scope		
if not indicated: needed for both models		
local radio front end	9512A*	1.—*
local radio IF	9689*	0.75*
local radio AF	9499-1*	0.70*
local radio psu	9499-2*	0.70
hi-fi dynamic range compressor	9395*	3.50*
IC power supply	9465*	1.65
TBA 120-T	9689*	0.75*

NEW**E23: MARCH 1977**

running light variometer tuner, front end	9203*	1.05
OTA-PLL (E7)	9447-1*	3.80*
scope calibrator	6029	1.25*
run rabbit, run!	9455*	0.30
	9764*	4.15

elektor publishers ltd

Due to the rapid expansion of our international organisation publishing ELEKTOR magazine in English, Dutch and German, a vacancy has arisen for a

technical translator

to assist the editorial section of our English edition.

The position involves the translation of articles on electronic topics from Dutch and/or German into fluent English. A sound knowledge of these languages is essential and some experience of electronic terminology would be an advantage.

The successful candidate will be based at our English offices in Canterbury. Salary is negotiable and attractive conditions of employment include assistance with removal costs, annual holiday bonus of 8.3% and Christmas bonus of 3%.

Applicants should write in the first instance with c.v. to

The Manager,
Elektor Publishers Ltd.,
6 Stour Street,
Canterbury,
CT1 2XZ

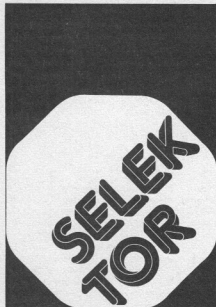

correspond to a period of a 'maximum-length sequence' is chosen in such a way that the chance that interference will cause the receiver to indicate a correspondence at the wrong time is at a minimum. This sync system is so insensitive to noise and other interference that synchronization is not lost until interference levels are reached at which the picture and sound have already become unacceptable.

In the first part D1 of the vertical flyback period D (figure 7), a continuous succession of 0's and 1's is transmitted for the purpose of effecting clock synchronization at the start of a call and establishing the black level. Only after this synchronization can the signal S1 and S2 be decoded. In the second part D2 of the vertical-flyback period many bit places are still not used. Ten lines are suppressed per field; D2 contains five of these in the experimental network but can be extended. Every line can accommodate 128 bits, 20 of which are needed for line synchronization and sound, which continue during the flyback period. That leaves 540 bit places per field, of which only 32 are used for field synchronization. A use can be found for the remaining bits. A modest start has been made in the experimental network by using 4 bits immediately after the 32-bit series to transmit the called subscriber's number, which is conveyed in digitally coded form to the exchange.

This still leaves an unused bit flow of approximately 25 kbit/s, but this could be employed to carry various kinds of information, not necessarily connected with the video-telephone call. An example of such information directly associated with the operation of the system would be a statement of the charge for a call or a warning that a third subscriber is calling.

an invitation to investigate, improve on and implement imperfect but interesting ideas.

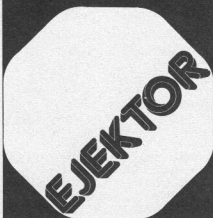

Negative feedback aided

by positive . . .

The dust blown off Llewellyn's US patent 2,245,598.

Almost any audio power amplifier can be considered as a combination of a relatively low-distortion voltage-amplifier (A_1) with an output stage producing relatively high distortion (A_2 with distortion d_2). In our case (see the figure), positive feedback is applied via path K_1 around A_1 . At the same time there is overall negative feedback via path K_2 . The equation for the output voltage V_u is given with the figure; there is no point here in dragging you through the derivation!

The term d_1 , d_2 describes the 'distortion of the distortion' — the distortion products d_1 produced by A_1

will be further distorted by A_2 . We see that something special is going to happen when $K_1 A_1$ is set equal to 1. The output signal will contain d_1 , reduced in the usual way by the overall 'feedback factor' — but the main distortion product d_2 will simply disappear! $K_1 A_1 = 1$ is of course the setting for which the gain stage would start to oscillate — if it were not prevented from doing this by the overall negative feedback. Now, the overall feedback will fail when $K_2 A_2$ goes to zero — for example when A_2 'clips' or during crossover 'notches'. (Be warned!) In a power amplifier using transistors the useful application of the principle would be to have $A_2 = 1$. To prevent wild things happening when A_2 saturates or crosses zero, two precautions are needed: (1) gain-failure during crossover has to be prevented by good class B biasing (preferably 'complementary symmetry' or its direct equivalent 'quasi-complementary-with-Baxandall-diode'); and (2) A_1 should be arranged to saturate before A_2 (for instance by using as an input stage a 'long-tailed-pair' biased by a current sink). The latter precaution will simply ensure that $K_1 A_1$ nulls first, so that the positive feedback fails before the overall negative feedback. There can then be no oscillation bursts during the drive cycle. Adhering to the above procedure does not, of course, absolve one from meeting the usual stability requirements.

The patent that describes the above principle dates from the mid-fifties, i.e. the Valve Age. One or two commercial amplifiers actually used it (Pye and Philips if we remember correctly) — but everybody else seems to have forgotten it, presumably due to preoccupation with the Dawn of the New Age (or with trying to persuade the essentials of the Transistor Age to dawn . . . ?).

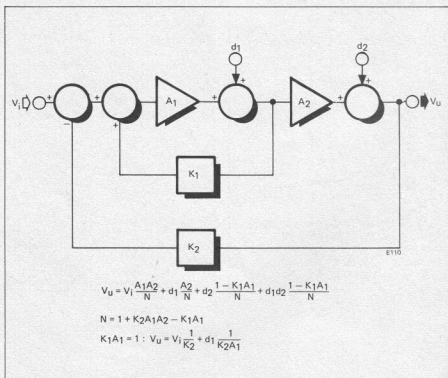

highlights

in the (near) future

Contributors to Elektor and the design staff in Elektor laboratories appear to be co-operating to create difficulties for our editorial staff . . .

In the last few months, we have been presented with several interesting projects for publication. This is normally a great relief for any editor - a continuing nightmare is the fear of not having enough at some future date. However, the difficulty at present is the exact opposite: not enough space in the magazine to pack it all in!

Having squeezed a complete description of the Elektroscope into three parts, we now have found room to start the articles on the variometer tuner and the morse decoder in this issue.

Next month, we intend to start a series on remote control of model cars. Up to four cars can be controlled via an infra-red link - this proves to be an ideal system for indoor use.

With a few modifications, the same proportional control system can be used for model trains, boats or aeroplanes. Space permitting, we will describe the necessary circuits for these applications as well.

In the May issue, we intend to start describing a further major project: the Elektor Synthesizer, alias 'Formant'. This is the design of a music synthesizer that offers the full range of musical possibilities of a medium-sized commercial synthesizer - at a fraction of the cost. The choice of components, the design itself and the availability of printed circuit boards make this a true home-construction project.

All in all, it looks as if the May issue will contain part 3 of the Variometer tuner, part 3 of the Morse decoder, part 2 of the Remote control system and part 1 of the Synthesizer. To keep the balance in that issue, a sufficient number of other interesting projects will have to be squeezed in as well . . .

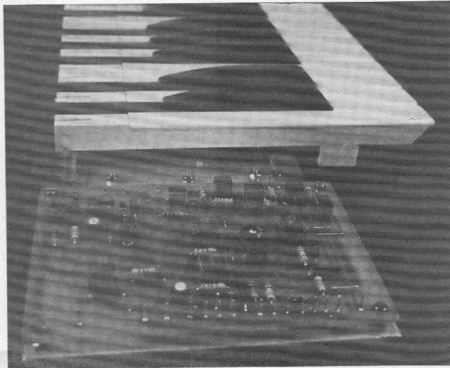
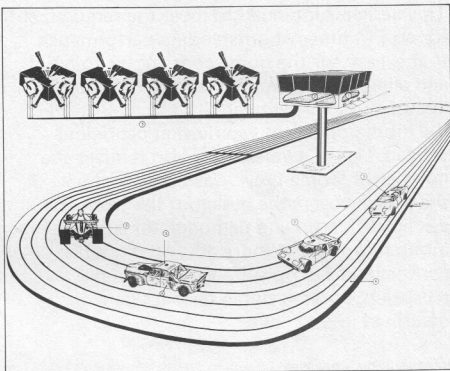

As if this was not enough, there are also articles in the pipe-line on such subjects as microprocessors, digital voltmeters, top-notch audio equipment and electronic games.

Our main worry now is that we may not be able to publish it all before the 'bright boys' come up with some new wild idea that deserves an exorbitant number of pages. We've asked them to calm down for the present and concentrate on smaller projects - but you never know . . .

■

VARIOMETER TUNER

(PART 1)

This design is intended to meet the requirement for an FM tuner of outstanding performance that is easy for the home constructor to build and align. For optimum stability of tuning the circuit employs permeability tuning instead of the more popular but somewhat capricious varicap. Use of a variometer also reduces the number of 'home-brew' coils. The first part of the article covers the design of the front-end and a simple i.f. strip and demodulator suitable for mono reception. A more advanced double-conversion i.f. strip suitable for stereo reception, and the stereo decoder are described in part two.

Introducing the Variometer

For those unfamiliar with permeability tuning a few words of explanation will not come amiss. The resonant frequency of an LC circuit may be varied by altering either the capacitance or the inductance. Variable capacitance tuning, either by varicaps or a mechanically variable capacitor, is the most popular method of tuning radios. However, permeability tuning was often used in early FM tuners, and is still used almost exclusively in car radios.

The variometer is an updated version of the old permeability tuners and consists of a number of coils (usually three) wound on a clear plastic former. Inside the former is a second plastic tube, threaded internally and containing three ferrite slugs. This tube can be moved along inside the first tube by means of a rack and pinion driven from a spindle attached to the outer tube. As the slugs move inside the coils the permeability and hence the inductance of the coils is varied. Two of the coils are used in the r.f. circuits of the tuner and the third is used in the local oscillator.

The variometer has considerable advantages over other tuning methods.

- because of its rigid mechanical construction it is electrically more stable than a variable capacitor, and certainly more predictable and stable than varicap diodes. AFC circuits were thus found to be unnecessary.
- it has an extremely high Q factor, which allows good selectivity with only two r.f. tuned circuits.
- the cost of a tuner using a variometer and fixed capacitors is less than the cost of one using a variable ganged capacitor and fixed inductors.

Front End

A great deal of thought was given to making the front-end sensitive, stable and easy to align. Various opinions have been aired in previous issues of *Elektor* about the pros and cons of bipolar versus field-effect transistors in r.f. circuits. Both types have their advantages and disadvantages, and bipolar transistors were used in this circuit because of their higher gain, easier optimisation of circuit parameters and ability to operate from a wider range of supply voltages.

Figure 1 shows the circuit of the front-

Specification

(measurements taken using variometer front-end with OTA PLL at a supply voltage of +12 V)

- Sensitivity for 26 dB S/N ratio:
0.5 μ V - 1.5 μ V at ± 20 kHz deviation (mono)
- 1 μ V - 2.5 μ V at ± 50 kHz deviation (mono)
- Maximum deviation: ± 100 kHz (input not less than 8 μ V)
- Image rejection: approximately 80 dB
- Maximum input level: 40 mV
- Gain: 35 dB - 45 dB
- Input impedance: 60 Ω or 75 Ω

end, which comprises three sections: r.f. amplifier T1, oscillator and buffer stage T3 and T4, and mixer and buffer stage T2 and T5. The input stage of the front-end is not sharply tuned, but has a bandpass filter which encompasses the FM band (Band II). This results in a slightly higher susceptibility to cross-modulation, but lower susceptibility to pulse noise than a sharply tuned circuit. C_X is not absolutely necessary but may give a better noise match to the transistor. It is advisable to leave it out until the alignment procedure has been completed. D1 and D2 protect T1 against excessive input signals.

T1 operates in the grounded-base configuration, with R4 as a collector 'stopper' to suppress any tendency to r.f. oscillation. Two sections of the variometer, L3 and L4, are used in frequency selective networks (L3, C5, C6 and L4, C8, C9) between T1 and T2.

Local Oscillator

The oscillator stage around T3 is a modified Clapp circuit, noted for its high stability. To avoid drift problems with temperature C20, C22 and C23 should be zero temperature coefficient types (NPO ceramic capacitors). The observant reader will note that the oscillator is designed to run at 10.7 MHz below the signal frequency, instead of 10.7 MHz above as is more usual. The reason for this will be explained later. To avoid pulling of the oscillator frequency by the incoming r.f. signal the oscillator output is buffered by emitter follower T4 before being fed to the base of the mixer transistor T2, together with the r.f. signal from C12.

Injection of the oscillator signal into the mixer transistor base allows effective heterodyning at much lower oscillator levels than would be possible with emitter injection or with a FET mixer stage. This, in turn, allows a much more stable oscillator circuit to be used than would be the case if a high output level were required.

Mixer stage

The mixer stage multiplies together the r.f. input and oscillator signals, producing sum and difference frequencies. Since only the 10.7 MHz difference

frequency is of interest the unwanted components of the mixer output must be filtered out. The resonant circuit comprising L6, C17 and C18 is tuned to 10.7 MHz (L6 is the only coil that must be home wound). The mixer output is buffered and amplified by T5, and a ceramic filter FL1 provides further 10.7 MHz selectivity. 10.7 MHz selectivity may also be provided in the succeeding i.f. amplifier stages if desired.

Supply decoupling

To avoid interaction between the front-end and other parts of the tuner the supply is decoupled by L7 and C25. To prevent interaction between the three sections of the front-end via the supply lines each section has its supply

455 kHz. The mixer is followed by a stage of 455 kHz selectivity. The 455 kHz signal is then fed into three limiting amplifiers in cascade. The outputs of these amplifiers are rectified and summed to provide signal strength indication and an output to a variable level muting stage. The output of the final limiting amplifier is fed to a PLL demodulator and thence via a birdy filter to the stereo decoder. This circuit will be discussed in more detail in the second part of the article.

The simple i.f. strip shown in figure 3 simply uses a PLL demodulator operating at 10.7 MHz. An optional signal strength indicator may be added. This circuit is suitable for reception only in mono.

Simple i.f. Strip

The i.f. amplifier and demodulator makes use of the 'Universal OTA PLL' described in Elektor 7, November 1975, and for further information on phase-locked loops readers are advised to consult this article and the article 'PLL Systems' in Elektor 3, April 1975. The advanced i.f. strip also makes use of the OTA PLL, with minor modifications, so readers may start by building the simple circuit and extend it later if so desired.

When using a PLL for FM demodulation the signal-to-noise ratio of the demodulated signal is proportional to the ratio of frequency deviation/i.f. frequency. A high i.f. frequency consequently means a poor signal-to-noise ratio.

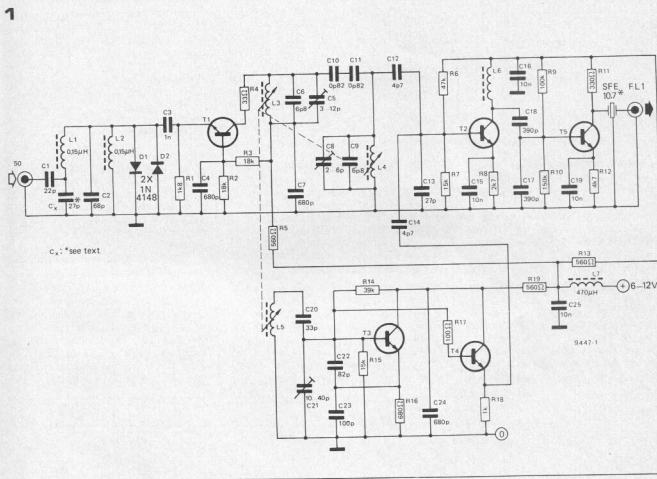

decoupled by R5, R13, R19, C16, C24 and C25.

Complete Tuner Design

The variometer front-end may, of course, be used in conjunction with any high quality i.f. amplifier and demodulator. Two circuits will be discussed in this article. Both circuits utilise a phase-locked loop demodulator, but the more advanced circuit uses double-conversion for a better signal-to-noise ratio, whereas the simpler version demodulates at 10.7 MHz. Block diagrams of both circuits are given in figures 2 and 3.

The advanced design takes the 10.7 MHz output of the front-end and performs a second mixing operation to bring the i.f. frequency down to

Figure 1. Circuit of the variometer front-end.

At an i.f. frequency of 10.7 MHz and 75 kHz deviation an acceptable signal-to-noise ratio can be obtained for mono reception. However, the s/n ratio for stereo reception is about 20 dB worse, and becomes unacceptable if PLL demodulation is carried out at 10.7 MHz. (Note, however, that a stereo transmission received on a mono receiver has the same s/n ratio as a mono transmission). The simple PLL demodulator is thus suitable only for mono reception. The circuit of the Universal OTA PLL is given in figure 4. The incoming i.f. signal is amplified by T1 and T2 before being fed into IC1, which functions as an amplifying phase comparator. The voltage-controlled oscillator (VCO) comprises T4 to T7, and the demodu-

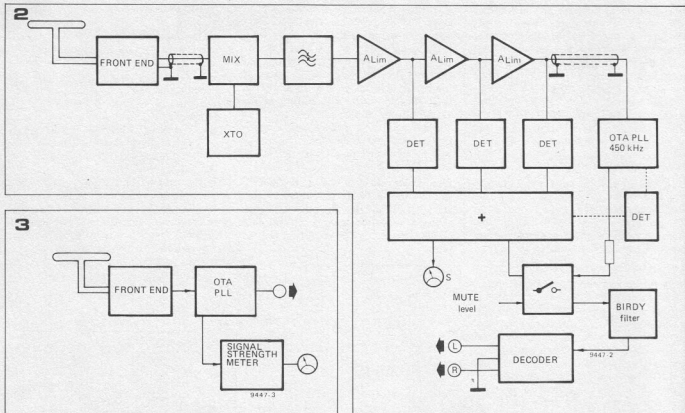

lated output (which is the VCO control voltage) is buffered and amplified by T8 and T9. Components that determine certain important parameters of the PLL such as input impedance, lowpass filter characteristic and VCO free-running frequency are shown starred. If and when the PLL is used in the double conversion i.f. system some of these values will have to be changed.

Construction

A printed circuit board and component layout for the OTA PLL are given in figure 5. This is of course, identical to the layout given in November 1975, so readers who already possess one of

these boards can use it if they wish in this new application. The circuit of an (optional) signal strength meter is given in figure 6. No board layout has been prepared for this but it can easily be constructed on Veroboard. If the intention is eventually to progress to the more advanced i.f. system this circuit will only be used temporarily.

Figures 7 and 8 show the p.c. board and component layout for the variometer front-end. For stability the p.c. board is double sided with the upper side being a ground plane. The lower side of the board also has a ground plane, and the two ground planes must be joined through the holes provided by wire

links that are soldered top and bottom. Little needs to be said about the components except to note that all capacitors must be ceramic types. A list of alternative transistor types is given with the preferred types first and alternatives in parentheses. L6 is the only coil that needs to be home wound and details are given in the parts list.

When constructing the front-end it is essential to keep component leads short. However, to avoid the possibility of inadequately insulated components shorting to the ground plane it is advisable to stand them off slightly from the board by placing a thin strip of card beneath components while

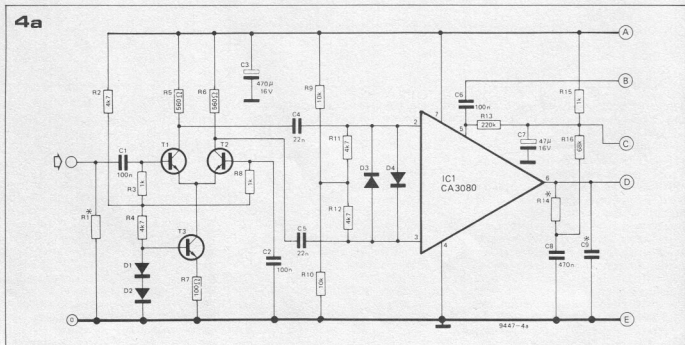

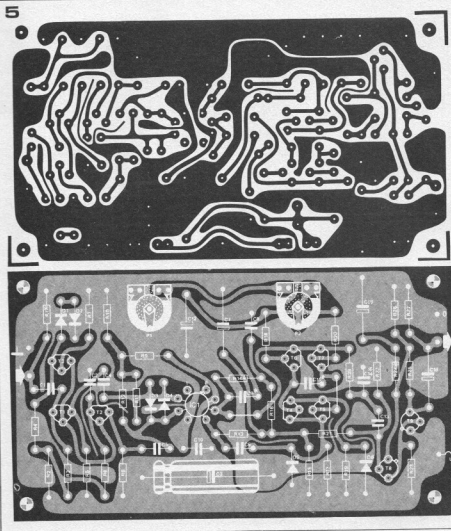

Parts list to figure 5

Resistors:

R1 = 330 Ω
 R2,R4,R11,R12,R28 = 4k7
 R3,R8,R15,R17,R18,R19,R20 = 1 k
 R5,R6 = 560 Ω
 R7 = 100 Ω
 R9,R10,R23 = 10 k
 R13,R22 = 220 k
 R14 = 47 k
 R16 = 68 k
 R21 = 470 k
 R24 = 33 Ω
 R25,R26 = 2k2
 R27 = 100 k
 P1 = 1 k
 P2 = 100 Ω

Capacitors:

C1,C2,C6,C10 = 100 n
 C3 = 470 μ /16 V
 C4,C5 = 22 n
 C7 = 47 μ /16 V
 C8,C13 = 470 n
 C9 = omitted
 C11 = 100 p
 C12 = 47 μ /10 V
 C14 = 10 n
 C15 = 100 μ /6 V
 C16 = 10 μ /10 V

Semiconductors:

T1-T7 = BF494, BF194
 T8 = BC547, BC147
 T9 = BC557, BC157
 D1-D6 = 1N4148
 IC1 = CA3080

Miscellaneous:

L1 = 470 μ H miniature r.f. choke

soldering. Connections from the aerial socket to the front-end and from the front-end output to the PLL input should be made using 75 Ω coax.

Constructing a neat dial drive for any radio can pose problems for the home constructor. Fortunately a simple system using only three pulleys can be

used with the variometer tuner, as shown in figure 9. This gives a very neat appearance. Pulleys and drive drums can be obtained from many component stockists, or failing this Meccano parts could be pressed into service. For clarity the drive cord is shown leaving the drive drum at a

different angle from that at which it enters. In practice, however, it should enter and leave in a straight line to avoid stressing the variometer shaft.

Power Supply

The variometer front-end will operate

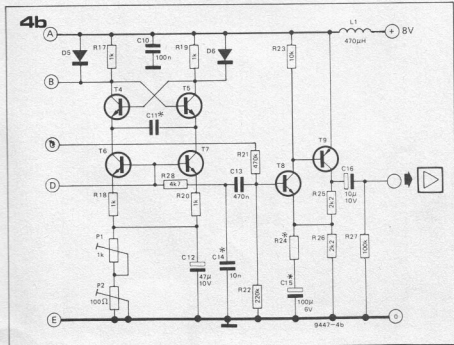
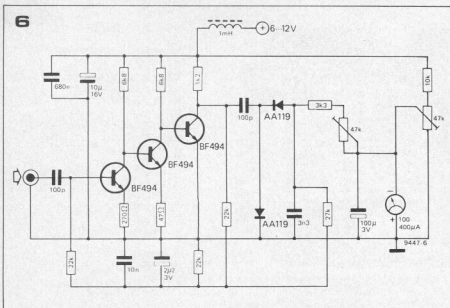

Figure 2. Block diagram of an advanced double conversion stereo tuner that will be described in parts 2 and 3 of this article.

Figure 3. Block diagram of a simple mono tuner using the OTA PLL described in November 1975.

Figure 4. Circuit diagram of the OTA PLL as used in the mono tuner. Note that certain component values must be changed if it is subsequently used in the stereo tuner.

Figure 5. Printed circuit board and component layout for the OTA PLL. (EPS 6029)



quite happily from any supply voltage between 6 and 12 V, but since the OTA PLL gives its optimum performance at around 8 or 9 V this was the voltage chosen for the mono version of the tuner, and a power supply circuit is given in figure 10. The stereo version of the tuner will, however, be operated from a 12 V supply, so the alternative component values for 12 V are given in parentheses.

Alignment

Since the front-end cannot, by itself, be aligned without sophisticated test gear the alignment instructions will be given only for the front-end plus OTA-PLL combination. This procedure can be carried out by ear, provided the circuit is functioning correctly.

1. Connect an efficient Band II aerial (VHF FM) to the aerial input of the tuner, and connect the output of the OTA PLL to an a.f. amplifier.

2. Adjust P1 and P2 to obtain maximum noise level from the OTA PLL

3. Adjust the core of L6 for maximum noise.

4. Tune to several strong stations over the FM band and adjust L5 and C21 so that the tuning range covers the entire FM band 87 to 104 MHz. L5 adjusts the lower limit and C21 adjusts the upper limit but there is some interaction between them and they may need to be adjusted several times. Since the upper part of the FM band is not used for broadcasting in the UK it will probably not be possible accurately to set the upper limit. In this case adjust L5 and C21 so that the stations that can be received are at the correct points on the tuning scale. If only a few weak stations can be received then go to 5 and 6 first.

5. Tune in a weak station (at around 90 MHz if possible) and adjust the cores of L3 and L4 to obtain minimum noise

level. To adjust L4 a trimming tool must be used whose shaft is a smaller diameter than its hexagonal end, since the tool must pass through the core of L3 or L5.

6. Tune to a weak transmission near 100 MHz and adjust C5 and C8 for minimum noise. If the transmitters are all received strongly then substitute a short piece of wire for the aerial to make the signal weaker.

7. Repeat 5 and 6 until no further improvement is obtained.

8. Tune to a weak station and adjust L6 for minimum noise level.

9. If desired try including C_x in the circuit to see if any improvement results. With the BF200 a value of 27 p gave optimum results. A 10-60 p trimmer could be used in place of C_x.

Test Results

The principal specifications of the variometer front-end plus OTA PLL are listed at the beginning of this article. However, the results of some additional measurements may be of interest.

Oscillator Stability

Tests were performed to establish the oscillator stability. It was found that over the supply voltage range 9 – 12 V the change in oscillator frequency was less than 22 kHz/V. The pulling effect on the oscillator frequency of r.f. input signals was also very slight. At an input level of around 3 mV the change in oscillator frequency was less than 1 kHz, rising to only 38 kHz with a 200 mV input.

Spurious Responses

Several measurements were taken using a spectrum analyser to check that any spurious responses were sufficiently well suppressed. The i.f. rejection of several samples of the variometer front-end was measured and found to be better than 70 dB in all cases.

Measurements were then made of the image rejection and these are of particular interest. Photo 1a shows the image rejection using an oscillator frequency 10.7 MHz above the incoming signal. The large peak in the centre of the trace is the response to the incoming signal, while the narrow spike just over two divisions or 10.7 MHz to the right is the oscillator signal. The image would be 10.7 MHz above the oscillator frequency or approximately two divisions to the right. It can be seen that the response at this point is some 45 – 50 dB down on the wanted signal. The centre frequency in this photograph is 93 MHz and the horizontal scale 5 MHz/div. The vertical scale is 10 dB/division. However, using a front-end with the oscillator 10.7 MHz below the signal gave some very interesting results, as shown in photo 1b and 1c. Here the oscillator spike is one division to the left of the signal, and the image would be about one division to the left of that. In this case the response is about 80 dB down or 30 dB better than when using

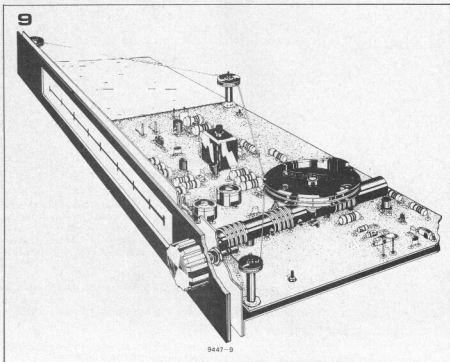

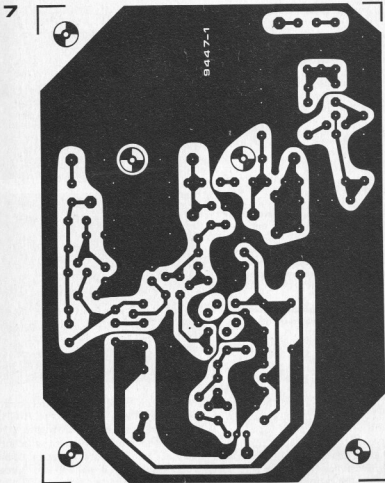

Parts list to figure 8

Resistors:

R1 = 1k8
 R2, R3 = 18 k
 R4 = 33 Ω
 R5, R13, R19 = 560 Ω
 R6 = 47 k
 R7, R15 = 15 k
 R8 = 2k7
 R9 = 100 k
 R10 = 150 k
 R11 = 330 Ω
 R12 = 4k7
 R14 = 39 k
 R16 = 680 Ω
 R17 = 100 Ω
 R18 = 1 k

Capacitors: (all ceramic)

C1 = 22 p
 C2 = 68 p
 C3 = 1 n
 C4, C7, C24 = 680 p
 C5 = 3-12 p (or 4-20 p) trimmer
 C6, C9 = 6p8
 C8 = 2-6 p (or 3-10 p) trimmer
 C10, C11 = 0.82 p
 C12, C14 = 4p7
 C13 = 27 p
 C15, C16, C19, C25 = 10 n
 C17, C18 = 390 p
 C20 = 33 p (NPO)
 C21 = 10-40 p (or 10-60 p) trimmer
 C22 = 82 p (NPO)
 C23 = 100 p (NPO)
 C_x = see text

Semiconductors:

T1 = BF200, BF314 (BF180, BF181, BF185)
 T2-T5 = BF494, BF324 (BF194, BF195, BF495)
 D1, D2 = 1N4148

Miscellaneous:

L1, L2 = 0.15 μ H r.f. choke
 L3, L4, L5 = Variometer VA-1826-1 (Vogt).
 Readers are advised to look out for advertisements in Elektor concerning this component.
 L6 = 14 turns 0.3 mm (approx 31 SWG) enamelled copper wire wound on Kaschke screened coil former type 12/12/14.5 or 12/12/16 with ferrite type K3/70/10 pink.
 L7 = 470 μ H r.f. choke.
 FL1 = SFE 10.7 MA or CFSA 10.7

Figure 6. A signal strength meter that may be used with the OTA PLL if desired. Its input may be connected to the collector of T1 or T2 in the OTA PLL.

Figure 7 on 8. Printed circuit board and component layout for the variometer front-end. (EPS 9447-1)

Figure 9. Suggested dial drive mechanism. Note that although for clarity the drive cord is shown entering and leaving the drum at different angles it should actually be in a straight line to avoid stressing the variometer shaft.

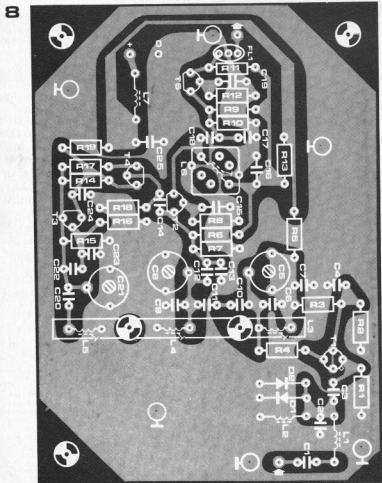

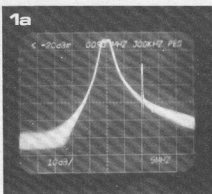

Figure 10. Power supply suitable for either the stereo or mono tuners.

Photo 1a. With the oscillator frequency above the signal frequency the image rejection of the variometer front-end is 45-50 dB.

Photo 1b. The variometer tuner is used with the oscillator frequency below the signal frequency since this gives an image rejection of 80 dB.

Photo 1c. Expanded view of the left-hand part of photo 1b.

Photo 2a. Signals at the aerial input with power switched off.

Photo 2b. Spurious signals at the aerial input using an oscillator frequency above the signal frequency.

Photo 2c. Spurious signals at the aerial input using a lower oscillator frequency than the signal frequency.

Photo 3. Intermodulation products from two signals 10 kHz apart are 45 to 50 dB down.

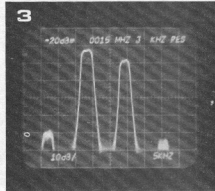
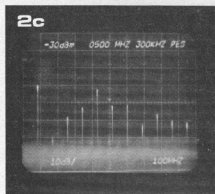
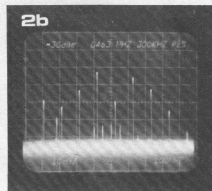
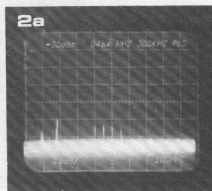
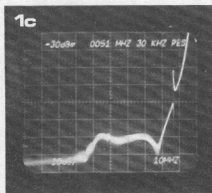
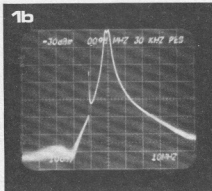

an oscillator frequency above the signal frequency. Photo 1c shows an expanded version of the left-hand part of the trace. In both these photographs the horizontal scale is 10 MHz/division and the vertical scale 10 dB/division.

For this reason the variometer front-end has its oscillator frequency unconventionally 10.7 MHz below the signal frequency.

The effectiveness of this system versus the conventional one was also investigated by looking at the spurious signals getting back from the oscillator and mixer to the aerial input. Photo 2a shows signals appearing at the aerial input with power to the tuner switched off. Photo 2b shows spurious signals generated by a prototype tuner using a higher oscillator frequency, while photo 2c shows that with a lower oscillator frequency spurious signals are about 7 dB lower. In each of these photographs the centre frequency is 500 MHz and the horizontal scale

100 MHz/division, so the frequency range covered is 100 MHz to 1 GHz. The vertical scale is 10 dB/division.

The final measurement on the spectrum analyser was to check intermodulation products. Photo 3 shows two signals 10 kHz apart (the two large peaks) at an input level of about 400 μ V for the right hand signal. The intermodulation products appear to the left and right of the two signals, and are some 45 to 50 dB down.

Further developments

The first part of this article has covered the design of the variometer front-end together with a simple i.f. strip that can be used to make an excellent mono radio for the car, for the home, or for portable use. In the second and third parts of the article will be discussed the design of a 'state-of-the-art' high-fidelity stereo tuner.

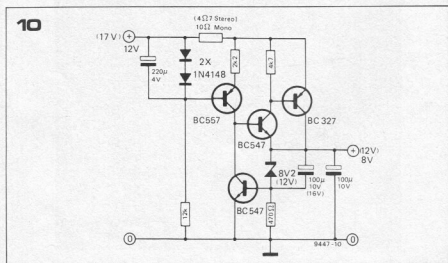

High Power Inverter using Gate Turn-off Thyristors

Using the new RCA G 5000 M gate turn-off thyristors an efficient, high-power DC/AC inverter can easily be built.

As most readers will probably know, conventional thyristors are extremely useful devices, but they do have their limitations. A thyristor requires only a small positive gate pulse at a current of perhaps a few milliamps to turn it on, but may control a current of hundreds of amps. The power gain of thyristors is typically tens of thousands.

Unfortunately, once a conventional thyristor is turned on the gate electrode has no further effect and the only way to turn off the device is to interrupt the current by some external means or to reverse the voltage applied to the thyristor. This makes thyristors fine for AC circuits, but not so good for DC applications. The gate turn-off thyristor,

as its name implies, may be turned on by a positive gate pulse, but may also be turned off by a negative gate pulse. This means that it is ideal for DC applications such as power inverters to convert power from a DC source such as a battery to AC power.

Figure 1 shows the output section of such an inverter. The four thyristors are arranged in a bridge configuration and the diagonally opposite pairs are triggered alternately by an external pulse generator. i.e. GT01 and GT04 are turned on together while GT02 and GT03 are turned off. GT02 and GT03 are then turned on while GT01 and GT04 are turned off, reversing the direction of current through the primary of the transformer. The turns ratio of the transformer can be chosen to step up the DC supply voltage to any desired AC voltage, remembering that since the output stage has a bridge configuration the peak-to-peak primary voltage across the transformer is twice the DC supply voltage, neglecting the slight losses in the thyristors.

The thyristors can switch currents of up to 8.5A, and since each thyristor is on for only half the time the RMS current in the transformer primary may be up to 17A. This means that with a 12V supply such as a car battery the maximum theoretical inverter output is about 200W (neglecting losses in the transformers). Using a higher supply voltage such as several 12V batteries in series even higher output powers may be attained, since the thyristors themselves will stand peak voltages of 600V.

Since at the instant of triggering it is possible for all four thyristors momentarily to be turned on a choke L1 is included in series with the battery to limit the current and avoid damage to the thyristors. A suitable value for this choke is:

$$L = \frac{1.75 V_{\text{supply}} \times 10^{-5}}{I_{\text{max}}} \text{ Henries.}$$

Where I_{max} is the current drawn from the supply under full loading of the inverter output.

At the instant of switchover from one pair of thyristors to the other the stored energy in the transformer can cause a large reverse e.m.f. to be generated, which could damage the thyristors. For this reason diodes D5 to D8 are provided to protect the thyristors. These clamp the voltage at points B and H to no more than $V_{\text{supply}} + 0.7$ and no less than -0.7 V.

Capacitor C3 provides filtering of the supply voltage and its value depends on the maximum supply current. The value given should be adequate for most applications.

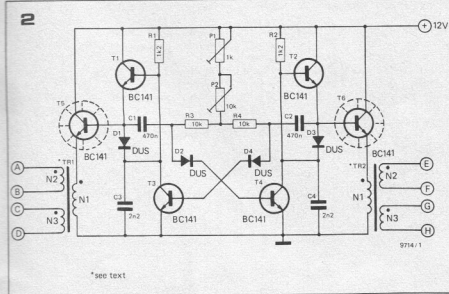
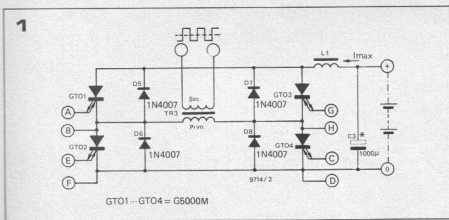

Figure 1. Output section of an inverter using four gate turn-off thyristors.

Figure 2. Trigger pulse generator for the inverter.

Trigger Generator

Figure 2 shows the circuit of the trigger generator. It comprises an astable multivibrator T3/T4, coupled to two output stages T1/T5 and T2/T6, which each drive a pulse transformer. The pulse transformers each have two secondary windings to provide trigger pulses for the four thyristors. Note that each pulse transformer supplies one diagonal pair of thyristors. It is important to ensure that the phasing of the pulse transformers is correct, otherwise more than two thyristors could be turned on simultaneously. P1 and P2 adjust the frequency of oscillation.

The prototype pulse transformers were wound on Siemens pot cores type B65651-K0250-A022, but any 18 mm or larger pot core with an inductance factor of about 250 nH/turn should be suitable. The winding details are as follows, using a three section former: Primary (wound on centre section):

80 turns 0.1 mm enamelled copper wire.

Secondaries (wound on end sections):

each 40 turns 0.1 mm enamelled copper wire.

All three windings on each transformer should be wound in the same sense to maintain correct phasing.

Choice of Output Transformer

The beauty of this type of inverter circuit is that the output transformer requires no special feedback windings, so an ordinary mains transformer connected 'back to front' is adequate for most applications. The choice of transformer depends on the required output current and voltage of the inverter.

Applications

The possible uses of inverters are too numerous to list. They can be used to power small mains appliances such as shavers and hairdryers while camping, to power small electric drills or to drive emergency fluorescent lighting. There are, however, one or two points worth bearing in mind. Firstly, since the output waveform of the inverter is a squarewave the RMS output voltage is equal to the peak voltage and is 1.414 times the RMS voltage of a sinewave of the same peak voltage. This means that for driving mains appliances the peak output voltage of the inverter should be equal to the nominal RMS mains voltage. Secondly, mains appliances having a motor should be driven from the correct frequency (i.e. 50 or 60 Hz), but fluorescent lights will operate more efficiently if the inverter is run at a higher frequency of several hundred hertz. Finally, when using an inverter for camping, never run it from the main car battery, unless you enjoy pushing the car. A 100 W inverter, for example, draws over 8A and would quickly discharge the battery. Rig up an auxiliary battery that can be trickle-charged from the car generator. **M**

SCOPE CALIBRATOR

It is comforting to believe in the infallible accuracy of one's test instruments, especially when there are no other standards around to contradict them. However, instruments, and particularly complex ones such as oscilloscopes, tend to drift with age, and if more than a year or so old can be highly inaccurate. This simple calibrator will check the gain and bandwidth of the Y amplifiers and attenuators and the frequency calibration of the timebase. It is so compact that it can be built into virtually any oscilloscope, making regular calibration a simple procedure.

Since the Y attenuators and timing capacitors in an oscilloscope are usually fairly stable components most of the drift generally takes place in the X and Y amplifiers and the rest of the timebase circuitry. Thus an oscilloscope will frequently agree with itself between different Y sensitivity and timebase ranges, even though the calibration may be wildly inaccurate with reference to an external standard. Gross discrepancies between ranges usually occur only in the event of a fault in the circuit and a drift in the overall calibration may go unnoticed for some time.

The simple circuit of the calibrator is given in figure 1. It consists of a 555 timer connected as an astable multivibrator with a period of 1.5 . . . 2 ms. This is gated on and off by T1, which is driven by a 50 Hz signal. The complete output waveform, shown in figure 2, comprises a burst of pulses (approx. 2 ms) followed by a 10 ms gap, followed by a further burst of pulses and so on. The time from the start of one burst of pulses to the start of the next burst is equal to the period of the 50 Hz waveform i.e. 20 ms. This can be used to calibrate the oscilloscope timebase.

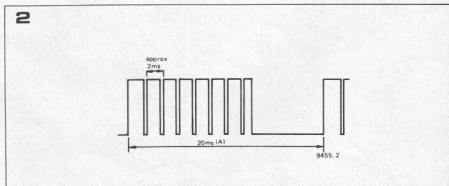

1

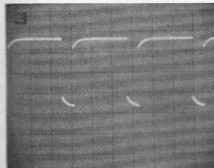
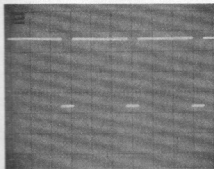
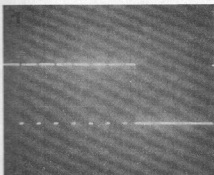
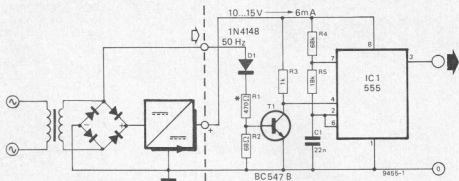

The amplitude of the calibration signal is approximately equal to the supply voltage, which can be measured with a multimeter. The amplitude of the waveform can then be used to calibrate the Y amplifiers.

The 2 ms pulses are useful for checking the bandwidth of the Y amplifiers and the compensation of the Y attenuators and also for calibrating oscilloscope probes. Photo 1 shows an oscillograph of the complete test waveform, while photo 2 shows the pulses as seen on a correctly calibrated oscilloscope. Photo 3 shows the effect of poor high-frequency response due to incorrect adjustment of the compensation trimmers in the Y attenuator.

Construction

A printed circuit board and component layout for the calibrator are given in figure 3. This is very compact and can be easily be mounted inside most oscilloscopes. It is assumed that the necessary supply voltage can be derived from the oscilloscope power supplies. With modern transistor oscilloscopes this should be no problem, the supply

can probably be derived from one of the low-voltage supplies in the oscilloscope either direct or via a simple zener stabilizer.

The anode of D1 is simply connected to one of the low voltage secondaries of the oscilloscope mains transformer. The values of R1 and R2 depend on the secondary voltage: R1 = 470 Ω up to 8 V; R1 = 680 Ω from 8 V to 11 V; R1 = 1 k from 11 V to 16 V; R1 = 1k5 from 16 V to 23 V; R1 = 3k9/2 W and R2 = 150 Ω from 23 V to 40 V. R2 = 68 Ω , as shown, up to 23 V.

Installation in older, valve-type oscilloscopes may pose a problem and it may be preferable to instal a separate power supply for the calibrator using a miniature mains transformer and a simple zener stabilized supply. Care should then be taken that the magnetic field of the transformer does not affect the performance of the oscilloscope.

The output of the calibrator can be brought out to a socket on the front panel of the oscilloscope so that the calibration can easily be checked by inserting a probe into the socket. ■

3

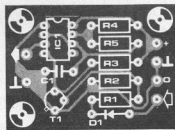
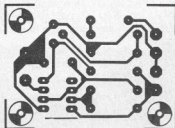

Parts List

Resistors:
R1 = 470 Ω *
R2 = 68 Ω *
R3 = 1 k
R4 = 68 k
R5 = 18 k
*see text

Capacitors:
C1 = 22 n

Semiconductors:
D1 = 1N4148
T1 = BC547B, BC107B
IC1 = 555 timer

Figure 1. Circuit of the calibrator.

Figure 2. Output waveform of the calibrator.

Figure 3. Printed circuit board and component layout for the calibrator.

Photo 1. Oscilloscope of the calibrator output waveform.

Photo 2. An expanded view of a portion of the waveform as seen on a correctly calibrated oscilloscope.

Photo 3. The waveform of photo 2 seen on an oscilloscope with poor h.f. response.

elektorscope in verocase

Several readers have expressed a wish to build the Elektorscope into a case that takes full advantage of the oscilloscope's modular construction. Fortunately, these requests coincided with the release of a new case/card frame system by Vero Electronics, and after consultation with Vero it was decided that this would accommodate the 7 cm CRT version of the Elektorscope. This article is intended to give readers an idea of how to go about building their Elektorscope into the Vero case.

A complete list of the Vero parts required is given at the end of the article to simplify ordering and readers are also advised to look out for Vero advertisements in the magazine.

The case/frame system will accommodate panel widths up to about 425 mm. However, since the four modules which make up the Elektorscope (CRT module, X module and Y modules) occupy only 275 mm of panel width, the remaining space may be filled with a blank panel or may be used to house probes or possibly another instrument such as a signal generator. The completed instrument is shown in figure 1.

The case/frame will accommodate 100 mm x 160 mm Eurocards such as the X and Y modules, and will also accept aluminium modules intended for heavier components. The CRT assembly is mounted in one of these. Snap-in guides to hold the cards or modules can be mounted at 5 mm intervals along the top and bottom of the frame. Since the modules have a greater height than the cards two types of guide are available, and these are given in the parts list. Figures 2 and 3 show the assembled case frame with the guides for the CRT module and the X and Y cards in position. Details of assembly of the case and insertion of the guides are given with the case frame, which is despatched in a 'flatpack' form.

Motherboard and X-Y amplifier

Along the top and bottom back extrusions of the frame are two tapped connector mounting strips. These can be used to mount the motherboard and X-Y output amplifier board. The mounting holes in these boards should be drilled oversize to allow slight positional adjustments.

Since the depth of the case behind the rear extrusion is limited the power supply board may not be mounted horizontally. Instead it can be mounted

vertically behind the motherboard on spacers. The connections between the power supply and motherboard can then be made using short wire links. The mains transformer can be mounted on the floor of the case at the rear right-hand corner. This is shown in figures 4 and 5. For servicing of the power supply it is necessary only to remove the two screws securing the power supply board to the spacers and the power supply can then be hinged down.

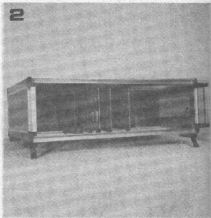

X and Y modules

Mounting the X and Y cards into the case presents few problems. The cards should first be checked to ensure that they are a smooth fit in the guides, and if they are slightly oversize the edges should be sanded down. After assembly the boards can be slid into the guides to check that the connectors mate satisfactorily with the sockets on the motherboard.

The next step is to mount the front panel trims on the X and Y front panels. The panels are fixed into the case by a captive screw at each corner, and in order to make the trims fit it is necessary to file a slot in each corner of the trim so that the trim will fit around the heads of these screws. The trim can then be fixed in position by a small self-tapping screw in the holes provided at the top and bottom of the trim. Once the trim is in position it can be used as a template for drilling the holes for the pots and switches.

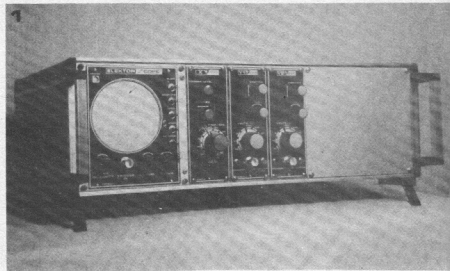

CRT Module

The next section to receive attention is the CRT module. Here again the trim can be used as a template for cutting the holes in the front panel. A hole must also be cut in the rear panel of the module to accept the neck of the tube. The face of the CRT can easily be correctly positioned by placing four small,

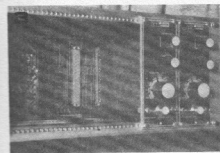

self-adhesive instrument feet around the edges of the hole in the front panel so that the faceplate of the CRT can sit between them. The neck of the tube can then be clamped by a capacitor clip (padded with foam draught excluder) mounted around the hole in the rear panel.

The high-voltage board is mounted beneath the CRT. The board is supported at its front edge simply by the spindles of the potentiometers that pass through the front panel. It can be fixed at its rear edge by two No. 6 PK x 5 mm self-tapping screws screwed upwards

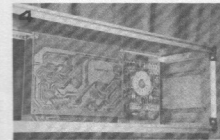

into the slot in the rear extrusion of the module (figure 6). For this method of mounting to work satisfactorily the pots must be compact p.c. mounting types, as the space between the potentiometer spindle holes and the bottom of the module is limited. If these are not readily available the best plan is to use ordinary pots secured to the board by small brackets so that the body of each pot is in contact with the board to make for minimum depth. Since the tags of the pots will now be uppermost the connections between the two outer tags and the p.c. board must cross over so that the controls still operate in the correct sense.

Between the CRT module and the motherboard are a number of connections, and to make the CRT module removable these should be sufficiently long to allow it to be withdrawn from the case after disconnecting the CRT socket. Alternatively a multiway plug and socket could be inserted in the middle of the wiring harness to allow the connections to be broken and the CRT module to be completely removed.

Vero Parts List

Item	Vero Part No.	Quantity
Case/frame	71-3869C	1
Module guides	35-0455H	1 packet (10)
Board guides	35-3083D	1 packet (10)
31 way plugs	17-0267H	3
31 way sockets	17-0268C	3
24E module (CRT)	39-3584E	1
10 front panels	39-0834E	3

Parts Ordering

A complete list of the Vero parts required is given above. Note that this consists only of the case/frame, CRT module, X and Y front panels, plugs and sockets, and guides. It does *not* include printed circuit boards and panel trims, which are obtainable from the EPS

service and are given in the current EPS list in Elektor. It does *not* include screws for fixing p.c. boards and front panel trims, nor the blank panel for the right-hand side of the case, though we understand that Vero might be willing to supply this if sufficient demand exists.

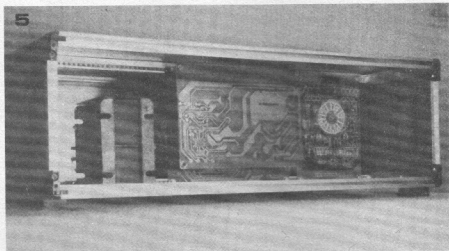

Figure 1. The completed Elektroscope in the Vero Case/Frame. Note the blank panel to the right of the Y2 module. A storage bin for test leads or another instrument could be mounted here.

Figure 2. View of the case with the CRT module and front panels removed, showing the X and Y boards mounted in their guides. To simplify dismantling for photography these pictures were all taken using blank p.c. boards without components or wiring.

Figure 3. Detail of the front of the case with CRT module and X module removed. The X-Y amplifier and the motherboard can be seen at the rear of the case.

Figure 4. Detail of the rear of the case showing the X-Y amplifier, the motherboard and the power supply board mounted on spacers behind the motherboard.

Figure 5. Rear view of the case showing the transformer, motherboard, power supply and X-Y amplifier.

Figure 6. The CRT module showing the high-voltage board mounted underneath. This is located at the front by the potentiometer spindles, and at the rear by two No 6 PK self tapping screws, screwed up into the slot in the rear panel extrusion.

Notes

1. Guides are sold packed in minimum quantities of 10, though only 6 board guides and 4 module guides are used in the Elektroscope. The spare guides may prove useful if another instrument is mounted in the same case as the 'scope.
2. Panels and modules are sold complete with handles, but these are not required in the Elektroscope.
3. Screws required to affix the motherboard and X-Y amp to the rear extrusions are metric M3 x 4. These can be obtained from any good engineer's supplier or the better ironmongers.

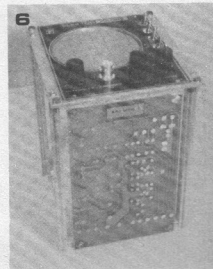

run rabbit run

A. Malchau

'Run Rabbit, Run' is a game of skill in which the object is to 'shoot' a 'rabbit'. Since both the rabbit and the gun are purely electronic this game is suitable for indoor use, with no danger of bullet-holes in the walls nor blood on the carpet.

The game is played by 'ambushing' the running rabbit from a chosen position. The position of the rabbit is indicated by a row of ten red LEDs that light up sequentially as the rabbit runs from his lair across the line of fire. In line with 9 of these LEDs are nine green LEDs representing nine firing positions. One of these positions may be selected by means of a rotary switch, when the selected LED will start to flash. The 'hunter' is also equipped with two push-buttons, one to 'load' his gun and one to 'fire' it. The object is to shoot at the

instant that the rabbit passes in front of the flashing LED. If a hit is scored the rabbit will stop and the green LED will burn continuously. A new firing position is then selected, the gun is reloaded and a new rabbit is set off on its run by pressing the start button. If the rabbit is not hit the gun must be reloaded and the shot taken again.

The game ends when a hit has been scored from each of the nine firing positions. The LED nearest the rabbit's lair is not used as a target position but simply to give the hunter warning as

Parts list

Resistors:

R1, R3 . . . R14 = 470 Ω

R2 = 1 k

P1 and P2 = 4k7

Capacitors:

C1 and C2 = 4 μ 7/6 V

C3 and C4 = 100 n

C5 = 470 n

C6 . . . C10 = 10 n

Semiconductors:

IC1, IC2, IC8, IC10, IC20 and

IC21 = 7400

IC3 and IC4 = 555

IC5 = 74190

IC6 = 7490

IC7 = 74121

IC9 = 7445

IC11 . . . IC15, IC17 and

IC18 = 7402

IC16 = 7410

IC19 = 7427

IC22 and IC23 = 7406

D1 . . . D10 = LED red*

D11 . . . D19 = LED green*

D20 = LED yellow*

* or colours to personal taste

Figure 1. Complete circuit of the game.

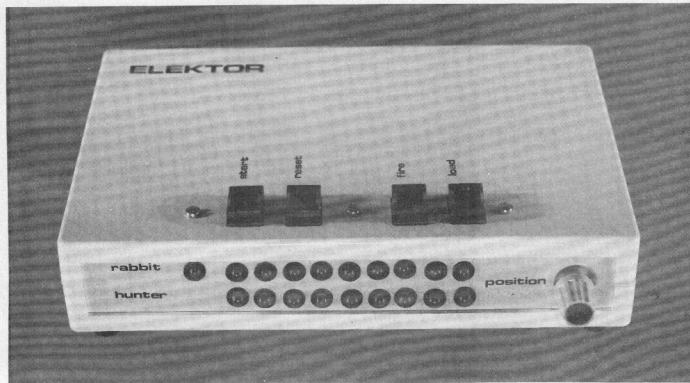

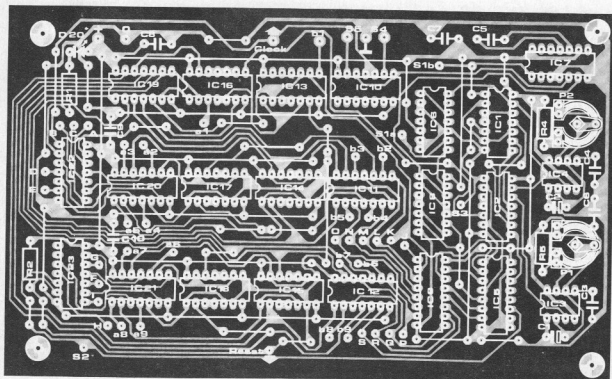
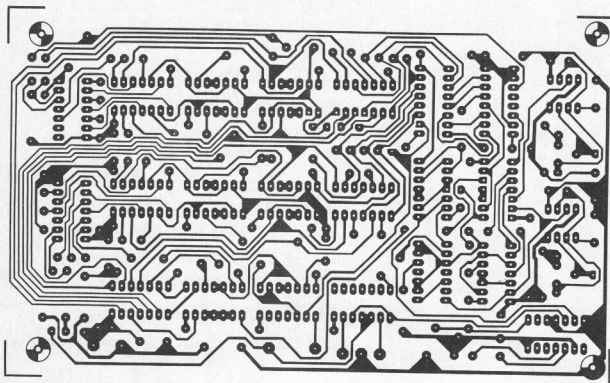

3

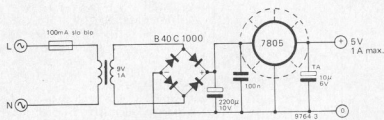

Figure 2. Printed circuit board and component layout.

Figure 3. Circuit of a suitable stabilised power supply.

the rabbit leaves the lair.

If desired the number of shots taken to complete the game may be recorded by an optional shot counter, or may simply be noted down on paper.

To make the game a little more difficult, if the rabbit is not hit then it will be startled by the shot and may alter both its speed and direction.

The circuit

Figure 1 shows the complete circuit of the game. The clock pulses that drive the 'rabbit' are provided by two 555 timers connected as astable multivibrators. The outputs of these two timers are NANDed together by N7. P2 is adjusted so that IC3 produces a lower frequency oscillation than IC4. The effect is that the IC4 frequency will appear at the output of N7, but gated on and off by IC3. The pseudo-random bursts of pulses thus produced will make the rabbit move in fits and starts (or possibly by leaps and bounds?). The output of IC4 is also connected direct to pin 13 of N1.

When the start button S4 is pressed flip-flop N3/N4 is set allowing pulses from N7 through N2 and N8 to the clock input of IC5. Flip-flop N5/N6 is also set, enabling the counter so that it counts the pulses. The counter outputs are decoded by IC9 and used to drive LEDs D1 to D10, which light up in sequence. Nine of the decoder outputs are also fed to the inputs of NOR gates N21 to N28, the other inputs of which are connected to the 9 positions of S1b. The pole of S1a is connected to the B output of counter IC6. This counter also receives clock pulses from IC4 and performs two functions. Firstly, its B output feeds pulses to the pole of S1a and thence (depending on the position of S1) to one of the NAND gates N14, N57-N64 to cause one of the LEDs D11 to D19 to flash. Pulses are also fed from its C output to pin 13 of N12, for a purpose to be explained later.

Firing Sequence

The gun is first loaded by pressing the 'load' button, which resets flip-flop N16/N17. When the 'fire' button is pressed this flip-flop is set which triggers monostable IC7. The output pulse of IC7 performs several functions. Firstly the low-going Q output is applied to the pole of S1b and thence to the input of whichever NOR gate is selected by

S1b. If the rabbit is in the desired position when the firing pulse occurs then the other input of the NOR gate will also be low. The output of the NOR gate will thus be high, setting the flip-flop connected to its output and permanently lighting one of the LEDs D11 to D18, so registering a hit. If a hit is scored then the output of N15 will go low, resetting flip-flop N5/N6 and stopping counter IC5. The Q output of IC7 also resets flip-flop N3/N4 allowing the output of IC4 through to the clock input of IC5, so that if a hit is not scored the rabbit will alter its speed.

The Q output of IC7 is connected to the inputs of N9 and N12. Depending on the state of the C output of IC6 this pulse may be gated through either N9 or N12 to set or reset flip-flop N10/N11. Since the output of this flip-flop is

connected to the up/down input of IC5 this may or may not reverse the direction of the count, depending on the original state of N10/N11.

When the game has been completed counter IC5 and all the flip-flops N26/N27 etc. may be reset by pressing the reset button. Clock and reset outputs are provided to drive an optional two-decade counter that may be used to record the number of shots. A suitable choice for this would be the universal counter/display module described in Elektor No 2, February 1975.

Power Supply

The power supply for the game must be regulated and capable of supplying up to 600 mA at 5 V (1 A with shot counter). A suitable circuit is given in figure 2 and could be accommodated on the p.c. board for the TV tennis power supply described in Elektor 7, November 1975. The circuit could alternatively be built on Veroboard.

Construction

A printed circuit board and component layout for the game are given in figure 3. To avoid the use of a double sided board a large number of wire links are used and care must be taken not to omit any of these or the circuit will not function. The lettered and numbered connection points to the LEDs and switches correspond to those shown in the circuit diagram. Note that resistor R3 is not mounted on the p.c. board.

Adjustment

On switching on and pressing the reset and start buttons the game should begin to function and it should be possible to select firing positions by means of S1. The only adjustments are to vary P1 and P2 until the speed of travel of the rabbit is acceptable.

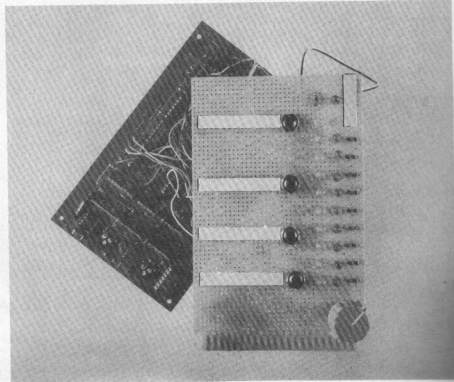

negative feedback

how thick to lay it on.

There are very many kinds of system in which the 'output' information is supposed to be proportional to the 'input' information. Linear systems, we call them. Most of them are however not quite linear. A power amplifier, for example, can noticeably distort the signal waveform and even add signal-unrelated information (such as 'hum').

Faced with such misbehaviour, the casual designer simply lays on the 'negative feedback'. It is all so simple: feedback reduces gain and unwanted products; the extra gain needed to offset the reduction of sensitivity is easily and cheaply obtained; end of unwanted output. This article is intended for the casual designer who has already burnt his fingers trying that approach. The rest of you, more knowledgeable (or more experienced!), may read on for their own amusement — and at their own risk! The following has only one pretension — to be **anything but** a textbook approach.*

An electronic circuit is a collection of active and passive components, arranged to perform a certain function. The circuit usually has an input and an output; you give it something to eat and it gives you the processed result. Oscillators can be viewed as circuits that eat their own output; they can also be viewed as selective non-linear amplifiers etc. The point is that they have no *apparent* input.

Although certain types of oscillator may actually employ a negative feedback amplifier, this discussion will have to be limited to circuits with an externally-

connected input (head) and an externally connected output (tail). It will also help if only *almost-linear* circuits are discussed.

A linear system is supposed to deliver an output that is proportional to the input signal. The simplest example in electronics is the voltage amplifier — shown in figure 1 as the well-known triangle. The output signal v_O is an A-times magnified copy of the input voltage v_i . Nothing has been said about the magnitude and behaviour-in-time of v_i . Suppose for example that $A = 1000$, so that 1 millivolt input will cause v_O to

equal 1 volt: if you apply a volt or so to the input, then the sparks should start to fly. Well, why not — it was a linear system . . . or wasn't it?

Not at that input level it wasn't. This is general point number two: the operating region within which the system remains (near-) linear must be kept in mind. The amplifier of figure 1 will typically saturate ('clip') at perhaps 10 volts output. It will also typically have a microvolt or so of input noise within the audio bandwidth; the input signal must be significantly greater if you want to do anything much with it. Some electronic systems deliver an output that has a dimension differing from that of the input. Some kind of convertor is attached to the circuit output as shown in figure 2, to enable it to produce an acceleration or a temperature rise (or anything else you care to imagine — quantified in units of, say, Smiths-per-hour to commemorate the genius Smith who first tried that particular conversion. The system 'gain' would then be expressed in $\text{Sm}/\text{h}/\text{V}$. There are clumsier concoctions around — such as 'heat sink dissipation' in British Thermal Units per Fahrenheit degree per Square Foot per Hour).

Let us now see what happens when negative feedback is applied. It will be helpful to represent a 'real' amplifier by the combination of an ideal system (as shown in figure 1 and 2) with a 'bug-generator' b as shown in figures 3 and 4. It is then assumed that b injects all the noise and distortion into the output signal.

What is feedback?

A system operating with 'feedback' has an *internal* input signal that is derived by combining the system input proper with a part of the output signal. Part of the output signal is *fed back* to the input, as illustrated in figures 5, 6 and 7. If the feedback acts in a way that reinforces the system input, it is termed *positive* (figure 7). In this case the internal input will be greater than the system input. When there is enough positive feedback applied, meaning that the internal gain more than offsets the division of the output signal, this output signal will build up in strength (possibly starting out from the always-present noise) until something saturates. The process is used in oscillators, the design requirements determining what it is that must saturate (and how) and whether frequency-dependent elements are used (as in sine-wave oscillators) or, instead, the charging time of a capacitor is used to set an interval between successive state-switchovers (as in multi-vibrators).

*Of the excellent 'textbook' approaches to the subject of negative feedback, we would mention that given in 'Precision Electronics' (Klein and Zaalberg van Zelst, Philips Technical Library). It is essentially complete while still remaining readable (the difficult bits are even set in smaller type!).

When the feedback opposes the original input it is termed *negative* (figures 5 and 6). The original input must then be made stronger to overcome the feedback, so that the system gain is reduced. This reduction of gain may be desired; if not it is readily overcome. The feedback will however also suppress unwanted signals originating inside the 'loop'. To see why this should happen, see figure 5.

Figure 5 shows negative feedback applied to the device of figure 3. The circle just to the right of the input terminal is a symbol indicating that the 'internal' input voltage e is equal to the input voltage v_i minus a fraction (k) of the output voltage v_o . We have $e = v_i - kv_o$. From figure 3 it will be clear that $v_o = Ae + b$. Figure 5 also gives the result of some rather messy algebra based on these two pieces of information. The gentle rain that falls from the heavens is now:

The ratio of v_o to v_i , that is the 'gain' of the circuit, has been reduced by a factor $(1 + Ak)$ compared to that of the same circuit without feedback. The factor $(1 + Ak)$ is known as the *reduction factor*; A is referred to as the *open-loop gain*, k as the *feedback factor* and Ak as the *gain inside the loop*.

The signal b appears at the output reduced by the same factor as the gain. Distortion products and spurious signals are therefore reduced to the same extent as is the system gain.

It is important to realise what is actually going on. There is no magic involved. All that happens is that the internal input voltage contains some b ; so that the amplifier proper is driven in a way that more or less neutralises the b trying to gatecrash the output.

Suppose that we have an amplifier, consisting of several stages; and that the unwanted signal b enters only in the final stage. We now observe the output waveforms of the various stages, with an oscilloscope, with and without the feedback connected. Without feedback (and without any input drive) we will find the unwanted b - in its full glory - at the amplifier output only. With feedback applied the disturbance at the output will largely have disappeared. All the other stages will however now be handling the neutralising signal, so that an unwanted waveform will appear at all internal signal-points. This will explain why an amplifier known to deliver full output at a distortion of perhaps 0.01% will show (may show) quite massive amounts of distortion at internal points. The 'clean' and well-behaved early stages are simply doing what they are supposed to do - neutralise the assumed misbehaviour of the output stage.

The above description has one fundamental incompleteness: it has not discussed the time taken for a signal to go around the loop. And all physical systems require a finite time in which to do things. We do not need any Mr. Einstein to explain that - one look at the lowly *frequency response curve*

will tell us all we need to know.

The frequency response curve will tell us for example that we cannot make the gain inside the loop, Ak , infinitely large in order to reduce b to precisely zero. Any practical amplifier will show a response curve for the open-loop gain A that falls off towards higher frequencies. (Amplifiers that are not DC-coupled also fall off towards the lowest frequencies.) The mechanism that causes this rolloff is also responsible for the finite time a signal needs to pass through the amplifier. When that time becomes comparable with the *period* of the high frequency (the time it takes to accomplish one cycle) the output signal will be significantly *shifted in phase* with reference to the input.

Now, if the phase shift reaches 180° at some frequency the feedback will have become *positive*. If the rolloff has not 'dumped' so much gain by then that

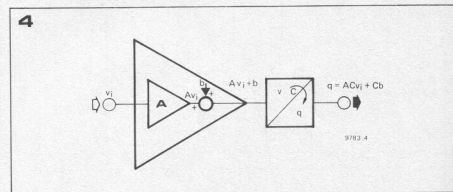
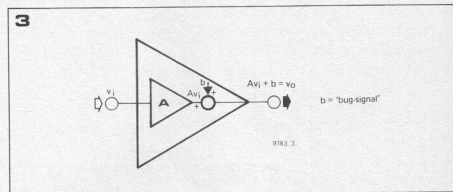
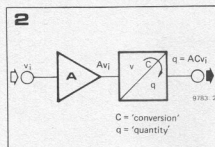
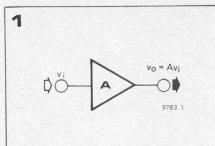

Figure 1. The symbol for an ideal linear system, such as an amplifier. The output is an image of the input, magnified by the system 'gain' A .

Figure 2. Some non-electronic quantity q , for which control is required, can be obtained from the combination of an electronic amplifier with a 'voltage-to- q converter'. When q is a movement the converter is usually called a transducer.

Figure 3. A real, and therefore non-ideal, system can be represented by the combination of an ideal system with a 'bug-generator' b . b is supposed to inject all the unwanted noise and distortion products that occur in practice - directly at the output.

Figure 4. The non-ideal electronic system of figure 3, extended with the voltage-to- q converter or transducer. To avoid adding another complication, the converter is assumed to be 'bug-free' - usually a gross distortion (!) of the reality.

the trip round the loop no longer shows a net 'profit' the amplifier will oscillate. Well before that stage is reached the system will start to show 'instability'. It can be shown that an optimal application of negative feedback to a given amplifier requires *very* careful tailoring of the open-loop frequency response.

Just how this has to be done can be derived from the mathematical work of people like Bode, Nyquist and Nicholls (and many others). The result of obeying the rules is that even less feedback effect can be achieved at high frequencies than the finite value of A (at those frequencies) would seem to imply.

The rules do not change when negative feedback is applied to the circuit given in figure 4 (see figure 6). The only complication is that, since the system output in figure 4 is of a 'different kind'

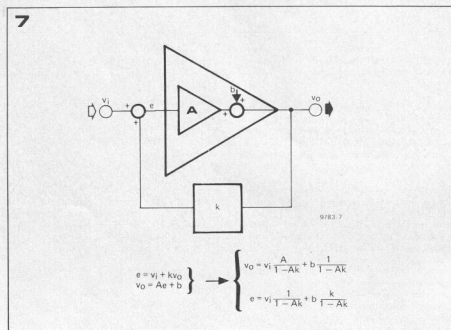
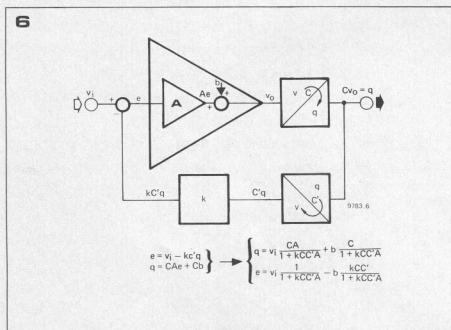
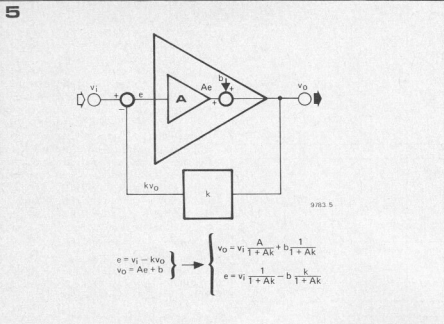

than the input, a second convertor (usually referred to as a 'sensor') is needed that will convert part of the output into a voltage — so that this can be subtracted from the system input, to effect negative feedback.

Going round the loop, in figure 6, we find that the electrical output of the amplifier causes the first convertor (transducer) to perform an action q . The sensor turns this action into a voltage Cq , that in turn is fed back to the amplifier input, where it opposes the input signal. The internal input e now drives the amplifier to deliver v_o to the transducer. It can be shown that any misbehaviour of the transducer v_o -to- q will be reduced by the feedback, according to the formulae given in the figure.

The use of a converting sensor in the feedback loop has one potential nasty consequence. If that sensor is in any way non-linear, or if it contrives to pick up any unwanted signal (e.g. vibration), the loop will drive q in an attempt to compensate the 'error'. The relationship between v_i and q will be *made non-linear by the feedback*.

One practical example of a system to which figure 6 applies is the so-called Motional Feedback Loudspeaker. In outline, the principle is that a flat frequency response, inside the woofer's useful working range is obtained when the cone-acceleration is made proportional to the system input voltage. In the latest commercial approach, an accelerometer-like device is mounted on the loudspeaker's coil-former, so that a suitable feedback voltage can be returned to the input of the power amplifier.

The Motional Feedback loudspeaker in fact demonstrates three characteristics of the operation of negative feedback.

Figure 5. Negative feedback added to the figure 3 set-up. The amplifier is now driven by an internal input voltage e , obtained by subtraction of a fraction k of the output voltage (v_o) from the system input v_i . From the formulae it will be seen that both the system sensitivity and the bug-injection are reduced by the factor $(1 + Ak)$.

Figure 6. The with-transducer system after application of negative feedback. The new element here is the 'q-to-voltage' sensor that reconverts the magnitude of the output-quantity q into a voltage suitable for feeding back. The feedback will reduce the real errors in the voltage-to- q convertor (by the factor $1 + Ak$) — but any error in the sensor will 'bug' the feedback process itself.

Figure 7. When a fraction of the figure 3 output is added to the input the feedback is positive. The formulae show how disaster can strike: if Ak equals or exceeds unity, the system will oscillate or (possibly) 'latch up'.

Figure 8. The relation between output and input signals in a 'clipping' system is shown at a. The levels V_1 and V_2 are equal, implying 'symmetrical clipping'. At b the 'bug-generator' operates to cause an error in the output at excessive input-drive levels.

Figure 9. A plot in time of the system input v_i , the output fraction kv_0 and the internal input e , for a negative feedback loop in which $Ak = 9$. The behaviour when there is no overdrive (no clipping) is shown at a; b shows the result of doubling the input voltage when the amplifier recovers instantaneously, so-called 'clean clipping' from t_1 to t_2 ; c shows the 'down for the count' delayed recovery, where even weak inputs are ignored until t_3 .

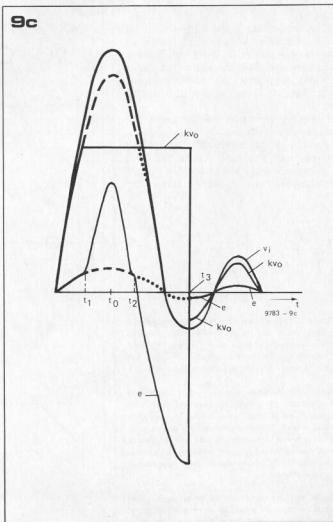
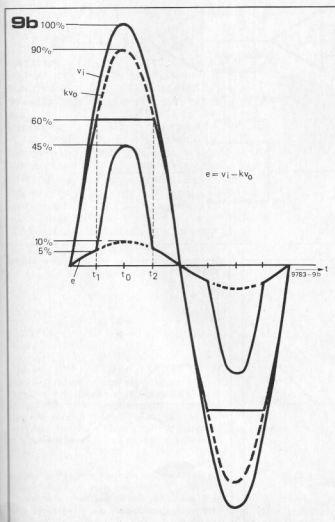
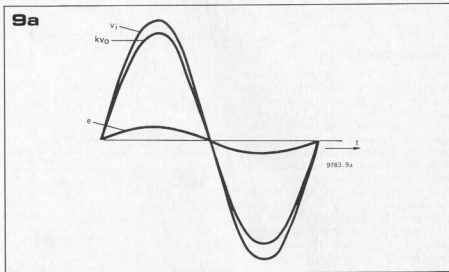
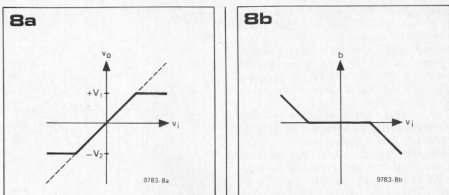

The apparent sensitivity of the system is reduced, first of all; a higher input voltage is needed to fully drive the power amplifier when the 'loop' is 'closed'. Secondly, the lower cut-off frequency of the system is reduced. Thirdly, the loudspeaker distortion is significantly reduced.

The MFB system demonstrates something else as well: the amount of feedback that can be applied without instability to a system that includes transducers (convertors) inside the feedback loop is quite small (in comparison with the tens of decibels usual in electronic-only loops). On the other hand, a distortion-reduction of 3...4 times is very well worthwhile!

Feedback that isn't . . .

It will be clear from the formulae in the figures 5 and 6 that the feedback operates by the grace of the 'open-loop gain' A . If there is no gain, then there is also no feedback. Put another way: when $A = 0$ there will be no AC output, even if an input is applied to the system. It is then meaningless to connect the output back to the internal input.

This is by no means a trivial remark. Two ways in which an amplifier's open-loop gain can (momentarily) become zero are when it is (1) driven into 'clipping' or (2) when it shows a 'dead zone' during 'crossover'. These cases are both worth a long, hard look.

Clipping

When the voltage at the output terminal of an amplifier attempts to follow an excessive input drive, there will come a point where the transistor (or other device) supplying the output current will 'bang its head against the supply rail'.

The curve in figure 8a illustrates the relationship between v_o and v_i for a figure-3-like (no feedback) circuit being driven 'into clipping'. Above the level V_1 and below the level $-V_2$, the output voltage v_o no longer follows the

10a

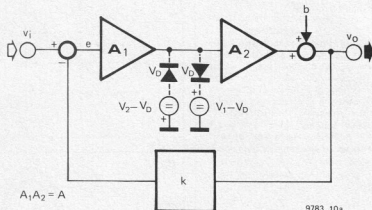

10b

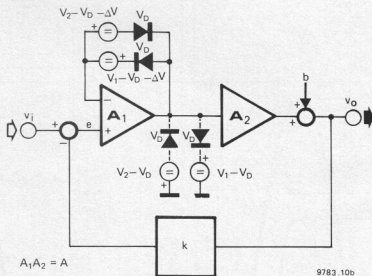

11a

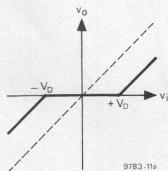

11b

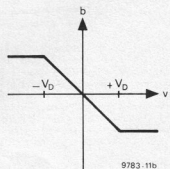

Figure 10a. The clipping in the unity-gain output stage A_2 is symbolised by voltage-offset 'clamping diodes' at A_2 input. The level at which the system 'runs around' is V_1 for positive and $-V_2$ for negative output swing.

Figure 10b. A rather clumsy — but illustrative — method of arranging that A_1 will clip 'cleanly' at a level just below V_1 (or just above $-V_2$). This prevents voltage surges and/or saturation occurring inside the feedback loop during severe input-overdrive, so that the amplifier will not need any significant 'recovery time'.

Figure 11. The relation between out- and input voltages in a system with a 'dead zone' (a) and the corresponding 'bug-signal' (at b).

intended (dashed) plot. In this example the clipping is *symmetrical*, V_1 and V_2 being equal. The horizontal asymptotes indicate where there is no gain and — briefly! — no AC output.

Figure 8b is a plot of the 'error' in v_o that occurs when v_i becomes excessive. This error is the signal b in figure 3. It is inside this excess- v_i region that there is no gain (and therefore no possibility of feedback).

When feedback is applied to a clipping system, it not only cannot help — it may actually make things worse. Figures 9a and 9b have been drawn for sinewave drive to a system having negative feedback with $Ak + 1 = 10$. The plots show a single period of three different voltages: the internal input voltage e , the system input v_i and the voltage fed back kv_o .

Figure 9a shows the situation when there is no excess drive: e is always $1/10$ of v_i , as a result of the subtraction of $9/10$ of v_i ($Ak = 9$).

The result of doubling the input drive is plotted in figure 9b. Clipping now occurs at 60% of the peak level of v_i . The plots for kv_o and e would, in the absence of clipping, follow the dashed paths.

From the instant $t = t_1$ onwards there will be no further increase of the negative feedback voltage (kv_o), as a result of output stage clipping. The internal input voltage e , normally 10% of v_i at the instant $t = t_0$, will now increase to 45% of v_i . That is a factor $4\frac{1}{2}$.

It will be obvious that the feedback is well-intentioned! 'Something seems to have stuck . . . if I bash it hard enough it may get back onto the dashed curve.'

The trouble is that good intentions do not help when a physical device has 'saturated'. On the contrary. The sharp corners in figure 8 are in actual fact slightly rounded off. With transistors however, this rounding is considerably less extensive than it is with thermionic valves; a couple of hundred millivolts will see you all the way from normal to zero open loop gain. The sharp edges in the figure symbolise the relatively sudden changeover from a situation that is normal to one of 'sorry . . . I just can't'.

Figure 12. The time-plot of the signals v_i , kv_o and e , for a feedback system with a dead zone. In practice the open-loop-gain is rarely precisely zero in the dead zone, so that the feedback does have some effect: it tends to 'sharpen' the usually somewhat rounded-off zone-edges.

Figure 13. Selective negative feedback can be useful when a very strong but precisely known bug-signal has to be squelched. The gain elsewhere in the frequency range is then not needlessly reduced.

12

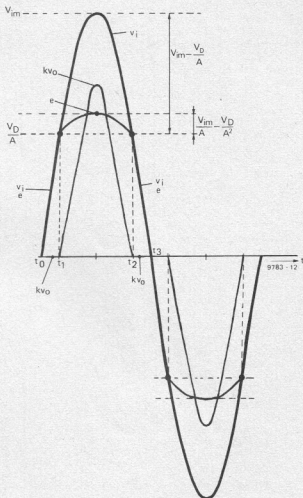

13

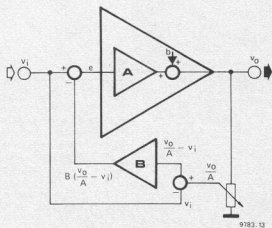

$$\left. \begin{aligned} v_o &= A e + b \\ e &= v_i - B \left(\frac{v_o}{A} - v_i \right) \end{aligned} \right\} \rightarrow \left\{ \begin{aligned} v_o &= A v_i + b \frac{1}{1+B} \\ e &= v_i - b \frac{B}{A(1+B)} \end{aligned} \right.$$

9783 13

All that the extra internal input voltage achieves is that the saturating device(s) are driven further into saturation (like a ship going full steam ahead into a sandbank). Now, when a transistor saturates, a bidirectional conducting path is set up between the collector and the emitter. This can result in a *positive* feedback effect, since the base voltage is normally in opposite phase to that at the collector, in which the device becomes 'permanently stuck' (so-called 'latch-up'). This means that the amplifier will not recover from the overdrive until the power supply is turned off. (Maybe not even then . . . you may have a spare parts bill to pay!) Even if there is no (semi) permanent latch-up, DC level-shifts in combination with resistor-capacitor networks in the vicinity, or the relatively long 'turn-off-time' of a saturated device, may cause the open-loop gain to stay 'down' well beyond the point at which the input overdrive is removed ($t = t_2$ in figure 9b).

One could say that the amplifier, once having 'banged its head' on the supply rail (or the 'chassis' — as may occur with negative overdrive and asymmetrical supply), will remain 'momentarily dizzy'. (Latch-up would be equivalent to concussion, I suppose . . .). During this *recovery interval*, the amplifier is (quite literally) 'down for the count' — until t_3 in figure 9c — and will not even respond to small signals at the input. In audio amplifiers, the delayed recovery effect is usually distressingly audible to everybody (except 'rock' fanatics, who actually like it . . . cor!), whereas 'clean' clipping with instantaneous recovery will often pass unnoticed, even in 'top-hifi'.

Negative feedback can, therefore, turn a normal phenomenon into a disaster. What can we do about this?

Figure 10a shows a two-stage amplifier in which the clipping points, $+V_1$ and $-V_2$, are symbolised by the clamping-diodes and sources of offset-voltage connected by the dashed lines. The symbolism assumes an ideal amplifier A_2 , with an error-signal source at its output to represent the AC failure when the diodes at the input 'clamp' the drive signal to the above-specified limits. In harmony with usual audio power amplifier practice, the voltage-gain of A_2 is unity ('voltage follower' output stage).

The circuit in figure 10b is derived from that in 10a by the inclusion of two more 'offset' clamping diodes. These introduce an additional 100% negative feedback around A_1 , that operates only when the signal from A_1 approaches within a couple of hundred millivolts of the A_2 danger limits. (That 'just within the danger limits' set-up is symbolised by the ' ΔV '). Since this extra feedback does not 'fail' at input-overdrive (on the contrary — that is precisely when it comes into action), A_1 will 'clip cleanly' just before A_2 . The recovery time will depend only on the 'limiter' diodes; it can be made negligible by the use of fast computer-type switching diodes. (Note

14

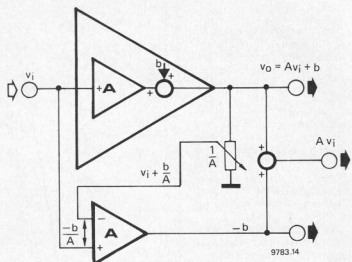

15

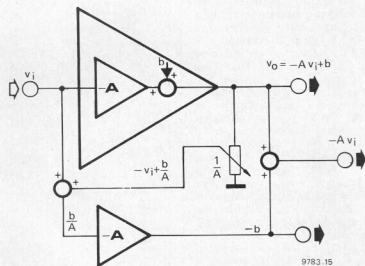

Figure 14. A system with feedforward error-correction instead of feedback. A separate error-amplifier detects the bug-signal present at the internal output, then adds a mirror-image of this directly at the feed-point of the load. This set-up applies to a greater-than-unity positive gain amplifier.

Figure 15. A feedforward system using an inverting amplifier.

that A_1 proper does *not* saturate.) In practice, the A_1 clipping function will be achieved even faster (and more cheaply) by using a *properly-designed* long-tail-pair-with-current-sink input circuit. (That, however, is another 'tail').

'Dead zone'

A second instance of useless feedback is when the system inside the loop has a 'dead zone'. This means that the internal system is only prepared to follow input signals that exceed a 'threshold' level (V_D in figure 11). The par-excellence example if this is a so-called class B audio amplifier biased to a too-low (or zero) quiescent current. ('So-called' because this incorrect-bias situation is really 'class C' — acceptable only in *tuned* power — amplifiers or oscillators.)

Figure 11a shows how the output voltage v_o only follows the input voltage v_i so long as this exceeds the threshold-values $\pm V_D$. The error-signal b corresponding to below-threshold drive is drawn in figure 11b.

To illustrate what happens when negative feedback is applied to such a system, the three voltages e , v_i and kv_o are plotted in figure 12 for a single sinewave input cycle.

The feedback operates normally (and beneficially) only in the interval between t_1 and t_2 . Inside the dead zone (t_0 to t_1 and t_2 to t_3), there is no output and therefore no feedback. The internal input e in this range equals v_i , not that it helps. . .

In a practical amplifier with an incorrectly biased (or simply incorrectly designed) output stage, the edges of the dead zone will not be quite so sharply defined as in figure 12. (The feedback will however tend, by a process analogous to that described under 'clipping', to make them so.) The open-loop gain inside the 'crossover' region, where one output device is approaching cutoff and the other should be taking over the load, may be lower than the value well away from crossover - it may even actually reach zero. The effect of the feedback is then to produce internal voltage surges that may cause something to clip (usually the first voltage-gain stage, that invariably 'runs dry').

This will produce a nasty, asymmetrical and high-harmonic-order distortion that is responsible for the 'gritty' sound of many transistor amplifiers at low output level. (A similar-sounding effect, *transient intermodulation distortion*, has a rather different bad-design cause and occurs at high-level higher-frequency drive. It deserves an article to itself, so we will pass over it here.)

To draw a conclusion: negative feedback will not turn a badly designed amplifier into a good one; it can however turn a basically good design into an excellent performer.

'Amplified feedback'

Figure 13 illustrates a fancy way of getting around the sensitivity-loss introduced by application of negative feedback.

A potentiometer is used to set a fraction of 'one A-th' of the output voltage, that is then subtracted from the system input voltage. The result is, in principle, a fraction $1/A$ of the 'bug-signal' - without any component of the 'wanted' signal v_i . This error-only signal may be amplified (in the 'bug-amplifier' B) and then applied in inverted sense to the internal input.

The result is negative feedback that suppresses only the unwanted noise and distortion products. The degree of feedback can be set by the gain of B, that replaces 'Ak' in the previous formulae. There is a disappointment in store for anybody who thinks that you can get away with more feedback this way: you can't - the amount of feedback that may be applied depends on the fre-

16

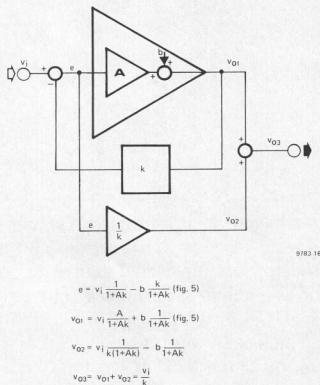

Figure 16. This circuit employs a combination of feedforward with conventional negative feedback. Use is made of the fact that the internal input voltage in the feedback loop (e) contains an error component that can be amplified separately and then injected at the load-connection - to precisely 'null' the bug-signal.

quency response of A. The usual rule, that the gain round the loop must have fallen to a safe value before the phase response has 'gone 180° ', still has to be obeyed!

'Error cancellation' or 'feedforward'

The main purpose of negative feedback is to get rid of the disturbance due to the 'bug signal'. The bother of carefully balancing parameters to maintain stability is the price that has to be paid for this achievement.

An entirely different approach will be briefly mentioned here. Since the 'bug signal' can be isolated from the wanted signal, one can separately amplify it and then add it in antiphase at the load-connection. This will cancel the

unwanted part of the 'main output'. Since there is no feeding back into the main channel, there is no longer any Mr. Nyquist to obey.

The process is actually used, under the names 'error cancellation', 'feedforward' and 'adding what is lacking'. The name you give it depends on what you want to use the process to achieve.

Figure 14 illustrates the idea for a non-inverting amplifier and figure 15 for an inverting type. A combination with normal feedback is shown in figure 16. The 'bug signal' is isolated by subtracting the $1/A$ fraction of the output voltage (of the main amplifier) from the system input. After exactly A times amplification this will cancel the error (assumed small compared to the main signal). The problem here is the need to combine two power outputs in a non-interfering way at the load feed point. This usually requires awkward transformer-type summing or subtracting circuits. \blacksquare

running light

This simple circuit will doubtless find any number of applications in the modern home. It can be used to bore unwanted guests, to annoy the cat, or as a conversation piece. The circuit drives 8 LEDs, 4 of which are always on and four off. The line of illuminated LEDs appears to move along as the LED at the tail of the line extinguishes and a new LED illuminates at the head of the column.

The complete circuit is shown in figure 1 and uses only two ICs and a handful of other components. The LEDs are driven by the outputs of the four latches in a 7475 quad latch IC. The Q and \bar{Q} outputs all have an LED connected to them, making 8 LEDs in all. The clock inputs of the latch are driven by a two phase clock, one phase being connected to IC2a and IC2c clock inputs, and the other being connected to IC2b and IC2d clock inputs.

Assume that initially S1 is in position 2 and all Q outputs are high and thus all \bar{Q} outputs are low. LEDs D1, D3, D5 and D7 are thus lit. On the phase one clock pulse the data on the \bar{Q} output of IC2d (i.e. 0) will be transferred to the Q output of IC2a, and the data on the Q output of IC2b (i.e. 1) will be transferred to the Q output of IC2c. The Q output of IC2a will thus become 0 while the other Q outputs will remain unchanged. Thus D1 will be extinguished and D2 will light.

On the phase two clock pulse the 0 on the Q output of IC2a will be transferred to the Q output of IC2b, and a new 0 will be transferred from the Q output of IC2d to the Q output of IC2a. D4 will thus light and D3 will be extinguished. D2 will, of course, remain lit.

This process will continue until all the even numbered LEDs are lit and the odd ones are extinguished. The \bar{Q} output of IC2d is now 1, so on the next phase one clock pulse a 1 will appear on the Q output of IC2a. This will go on until all the Q outputs are 1 again, when the cycle will repeat.

If S1 is set in position 1, a logic 1 will

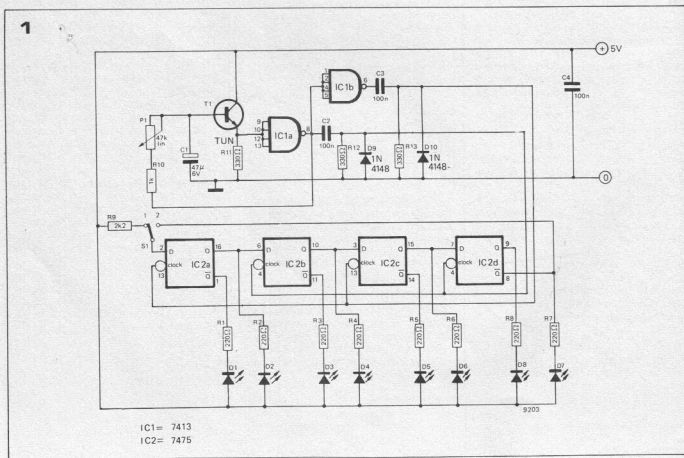

2 Parts List

Resistors:

R1 to R8 = 220 Ω
 R9 = 2k2
 R10 = 1 k
 R11 to R13 = 330 Ω
 P1 = 47 k lin pot.

Capacitors:

C1 = 47 μ 6 V
 C2 to C4 = 100 n

Semiconductors:

T1 = TUN
 IC1 = 7413
 IC2 = 7475
 D1 to D8 = LED e.g.
 TIL209 or similar
 D9 and D10 = 1N4148

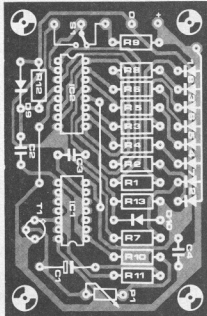
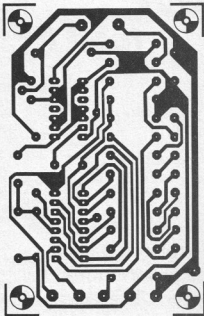

be present at the input of the first flip-flop, regardless of the output state of the fourth flip-flop. By manipulating this switch, various patterns can be set up; if the switch is then set (and left) in position 2 the pattern will be 'clocked round the loop'.

The two phase clock is generated using a 7413 Schmitt trigger. IC1 is connected as an oscillator, with T1 acting as a buffer to increase the input resistance seen by C1. The positive-going edges of the IC1a output waveform are differentiated by C2 and R12 to give short positive going spikes which are used as the phase two clock pulses. The output of IC1a is inverted by IC1b to give a positive-going edge on the negative edge of the IC1a output. This output is differentiated by C3 and R13 to give the phase one clock pulses.

A printed circuit board and component layout for the walking light are given in figure 2. The LEDs need not be mounted direct on the board but can be arranged in a ring, square or other pleasing arrangement if so desired. A 5 V stabilised supply such as the TV Tennis power supply may be used to power the circuit (EPS 9218a).

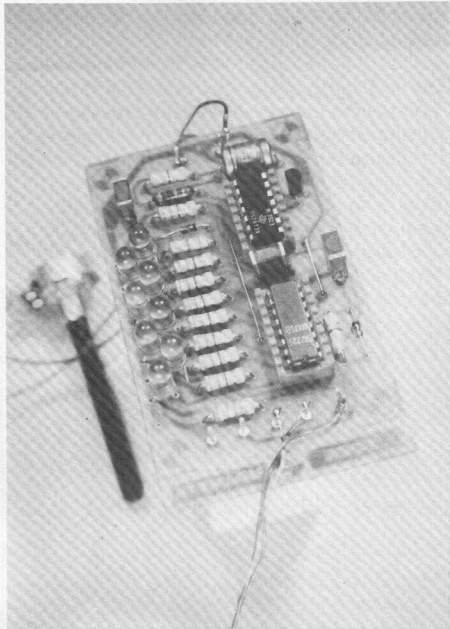

Figure 1. Circuit of the Running Light.

Figure 2. Printed circuit board and component layout for the Running Light. (EPS 9203)

morse decoder with ddll (part 1)

E.H. Leefsma, PA ϕ KTV

The February 1976 issue of Elektor contained a design for a decoder that would convert morse signals into alphanumeric characters. The disadvantage of this system was that the decoder had to be manually synchronised to the sending speed, which meant that it had to be individually adjusted for each incoming message and could not adapt to variable sending speeds. The new design is equipped with DDLL (Dot-Dash-Length-Logic), which automatically synchronises the decoder to the sending speed. The decoded morse signal is presented in a binary code that may be further processed digitally to drive a teleprinter, visual display terminal or other display. A simple display using seven segment LED displays and utilising the 'seven segment alphabet' described in Elektor July/August 1975 will also be described.

The morse signal from the receiver, which will generally be in the form of an audio tone, must first be converted into a series of pulses that can be processed digitally. Short pulses represent dots and long pulses the dashes. Various combinations of dots and dashes of course make up characters in the morse alphabet. Between dots and dashes and between letters and words are spaces of varying duration.

A space within a character is nominally of one dot duration, a space between letters of one dash (= three dots) duration, and a space between words of five to seven dots duration. Of course the speed of sending may vary greatly, depending on the skill of the sender, and the lengths of the dots, dashes and spaces may not always be correct. The decoder must thus be able to synchronise itself to any reasonable sending speed, and also compensate for variations in the duration of the character elements.

Block Diagram

Figure 1 shows a very simple block diagram of the morse decoder. The incoming morse signal is first 'cleaned up' to remove noise and convert the signal to TTL compatible logic levels. It is then fed to a central processor, which controls the whole decoder. Each character element is fed to the dot-dash-duration-detector, which determines if the character is a dot or a dash. The detector gives a '0' output for a dash and a '1' output for a dot, and these '0's and '1's are fed to a serial-in parallel-out shift register which stores them. At the end of a character, that character is thus available in parallel form at the outputs of the shift register. It is still in Morse format, though the dots and dashes have now been converted to a series of logic 0's and 1's in the shift register (see Table 1).

Using a read only memory, the code available at the shift register output may be converted into any of the international standard codes such as ASCII, teletype (BAUDOT) code etc. suitable for feeding into the display unit.

The block diagram of the decoder is expanded further in figure 2. The most important section is, of course, the Dot-Dash-Duration-Detector at the right of the diagram. This operates by comparing the duration of the incoming character element with the duration of the previous character element, and for it to operate at least one dot and one dash (or spaces of corresponding length) must have been received.

The 'reference duration' is equal to two dots. If the previous character is a dot then a digital count equal to twice its duration is stored in a register for comparison with the next character element. If the character element is a dash the 2/3 of its length is stored for comparison with the next character element. Since the 'reference duration' is always equal to two dots all that is necessary is to compare the reference element with the incoming character

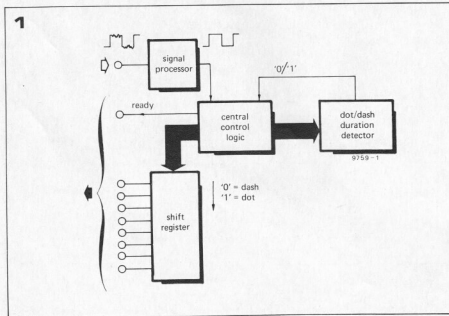

2

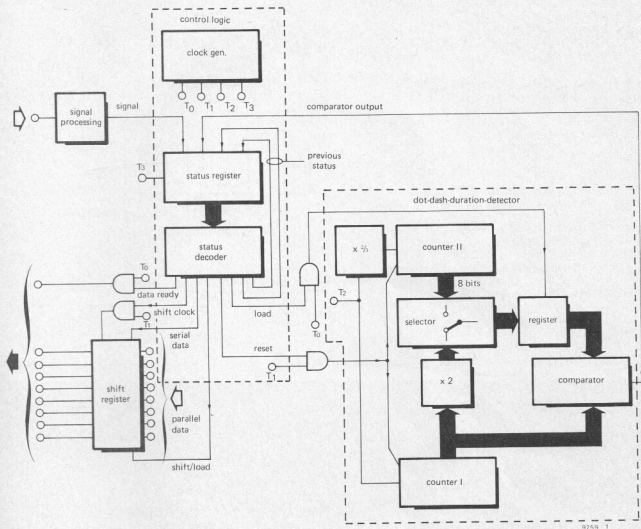
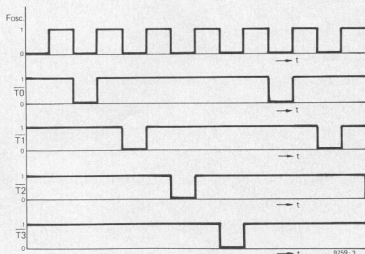

Figure 1. Simplified block diagram of the morse decoder.

Figure 2. More detailed block diagram of the decoder showing the operation of the Dot-Dash-Duration-Detection logic. The operation of the detector is directed by the status register under the control of a four-phase clock generator.

Figure 3. Four-phase outputs of the clock generator.

3



9759-3

4

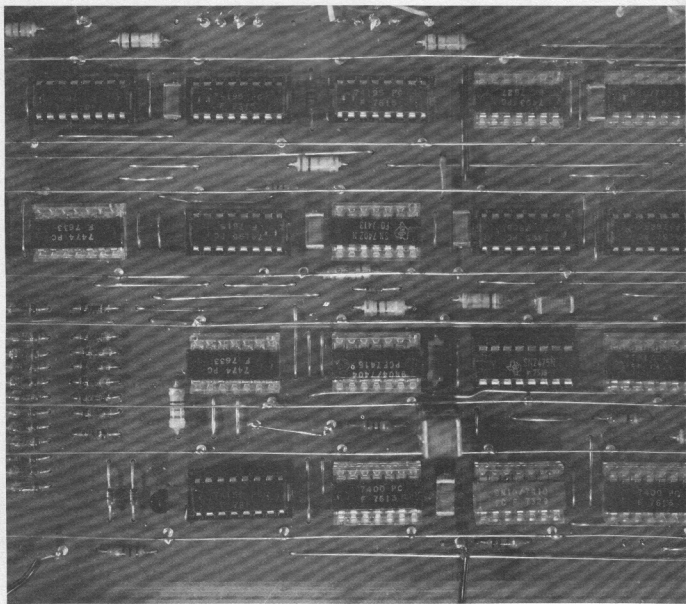
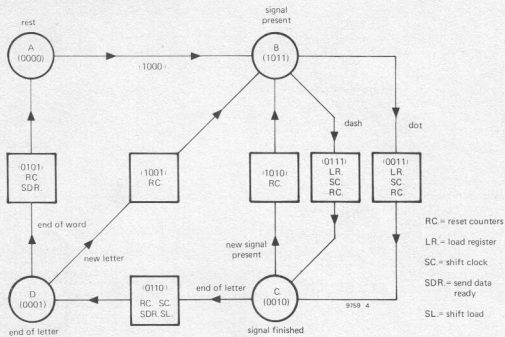

Table 1.

		Q8	Q7	Q6	Q5	Q4	Q3	Q2	Q1
...	A	1	1	1	1	1	0	1	0
...	B	1	1	1	0	0	1	1	1
...	C	1	1	1	0	0	1	0	1
...	D	1	1	1	1	0	0	1	1
...	E	1	1	1	1	1	1	0	1
...	F	1	1	1	0	1	1	0	1
...	G	1	1	1	1	0	0	0	1
...	H	1	1	1	0	1	1	1	1
...	I	1	1	1	1	1	0	1	1
...	J	1	1	1	0	1	0	0	0
...	K	1	1	1	1	0	0	1	0
...	L	1	1	1	0	1	0	1	1
...	M	1	1	1	1	1	0	0	0
...	N	1	1	1	1	1	0	0	1
...	O	1	1	1	1	0	0	0	0
...	P	1	1	1	0	1	0	0	1
...	Q	1	1	1	0	0	0	1	0
...	R	1	1	1	1	0	1	0	1
...	S	1	1	1	1	0	1	1	1
...	T	1	1	1	1	1	1	0	0
...	U	1	1	1	1	1	0	1	0
...	V	1	1	1	0	1	1	1	0
...	W	1	1	1	1	0	1	0	0
...	X	1	1	1	0	0	1	1	0
...	Y	1	1	1	0	0	1	0	0
...	Z	1	1	1	0	0	0	1	1
...	1	1	1	0	1	0	0	0	0
...	2	1	1	0	1	1	0	0	0
...	3	1	1	0	1	1	1	0	0
...	4	1	1	0	1	1	1	1	0
...	5	1	1	0	1	1	1	1	1
...	6	1	1	0	0	1	1	1	1
...	7	1	1	0	0	0	1	1	1
...	8	1	1	0	0	0	0	1	1
...	9	1	1	0	0	0	0	0	1
...	0	1	1	0	0	0	0	0	0
...	.	1	0	1	0	1	0	1	0
...	-	1	0	0	0	1	1	0	0
...	?	1	0	1	1	0	0	1	1
...	[1	1	0	0	1	0	1	0
...]	1	1	0	1	0	1	0	1

Figure 4. Flow diagram showing the operational sequence of the decoder and the various states of the status register.

Table 1. Showing the Morse characters reduced to 0's and 1's as they appear at the outputs of the shift register. Note that the start of each character is always preceded by a 0, so A (.-) is not 11111110 but 11111010.

element. If the character element is shorter then it is a dot. If it is longer then it is a dash.

How the Dot-Dash-Duration-Detector operates in detail can be seen from figure 2. Two counters I and II receive pulses from the system clock generator. The counters are both gated by the incoming signal, i.e. they count during a dot or dash. Counter II counts only two out of every three clock pulses, so its count is always 2/3 that of counter I. At the end of the character element the contents of counter I are compared with the contents of a register which contains the 'reference duration'. If the count in counter I is greater than the number stored in the register then the comparator output is '0' for a dash. If the count in counter I is smaller then the comparator output is '1' for a dot.

If the result is a dot then counter I

obviously contains a number corresponding to one dot duration. This is therefore doubled and fed via the selector into the register to be the two dot reference duration for the next comparison. If the result is a dash then counter II obviously contains a number equal to 2/3 of a dash i.e. two dots. This is therefore fed via the selector into the register as the next reference duration.

The fact that the reference is updated on each character element means that the decoder can very quickly adapt to varying sending speeds.

Clock Generator

The central control unit is driven by a four-phase clock generator operating at about 4 kHz and controls the functioning of the Duration Detection logic and the loading of the decoded dots and dashes as 0's and 1's into the shift register. It also provides a strobe output to indicate that the data in the shift register is valid, and the 4 kHz clock is also used to provide an interference free Morse audio signal.

A 'four-phase' clock simply means that the clock generator has four outputs. The second output lags the first by 90°, the third output lags the first by 180° and the fourth output lags the first by 270°. The output waveforms of the clock generator are shown in figure 3.

Status Register

The sequence of operations in the decoder is controlled by a four bit 'status register' that provides all the control commands within the decoder. Before looking at the circuit in more detail it may be helpful to study the flow diagram of figure 4, which shows the sequence of operations in the decoder with reference to the output states of the status register.

With no Morse input signal the status register is in the rest position 'A' (0000). On receipt of a signal (dot or dash) it goes to state 'B' (1011) and allows the counters to count clock pulses. On completion of the dot or dash the register either goes to 0011 or 0111 depending on whether the character element was a dot or dash. In either case the counters are reset and the dot or dash is loaded into the shift register. Depending on whether the character was a dot or dash either the contents of counter I or twice the contents of counter II are loaded into the reference duration register, and the status register goes to state C (0010).

The duration of the space is now computed. If this is less than two dots, the character is not complete and the status register goes back to B and repeats this loop. As soon as a space lasts for more than two dots the character is complete and the status register goes to D (0001). It then goes back to B to start the next character, unless the word is complete (space longer than four dots) when it goes back to A.

The complete circuit of the decoder will be given in the second part of this article.



Schottky detector diodes need no DC bias

These new zero-bias Schottky diodes from Hewlett-Packard eliminate the problem of temperature compensation of DC currents required in sensitive circuits using conventional detector diodes.

The high, zero-bias voltage sensitivity of these diodes makes them especially suitable for narrow-bandwidth video detectors such as in high-frequency receivers and measurement equipment.

The HSCH-3000 Series diodes have a typical voltage sensitivity of 10 to 50 millivolts of output per microwatt of input power (depending upon device type) at 10 GHz. Conventional Schottky detector diodes with DC bias applied produce 5 to 10 millivolts per microwatt.

Both low impedance (2000 to 8000 ohms) and high impedance (80,000 to 300,000 ohms) devices

are available. The HSCH-3000 diodes are available in either ceramic or glass axial lead packages.

*Hewlett Packard,
P.O. Box 349, CH-1217
Meyrin 1 Geneva, Switzerland.*

Integrated transistor arrays

Philips' TDA3081 and TDA3082 transistor arrays are monolithic integrated circuits consisting of seven separate n-p-n transistors on a common substrate. They are

particularly suitable for driving light emitting diodes and seven segment displays, as well as numerous general purpose applications.

The transistors are individually capable of driving loads up to 100 mA with a maximum dissipation of 500 mW per transistor, or a total package dissipation of 750 mW maximum. In the TDA3081, the transistors are connected in common emitter configuration, while in the TDA3082 the collectors are in common.

The transistor geometry used gives maximum current gain at

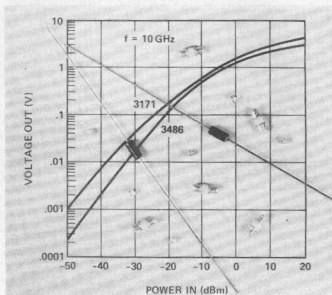
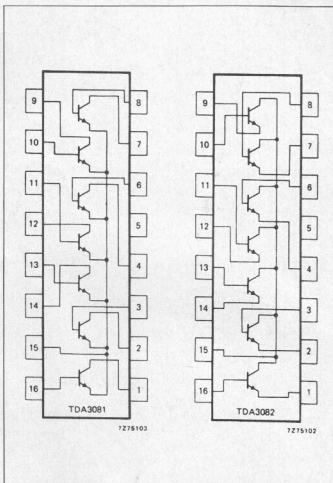

quite low currents making the devices suitable for small signal applications. V_{CB0} is 50 V maximum and V_{CE0} is 35 V maximum. The devices are encapsulated in 16-pin DIL plastic packages.

*Philips, Elcoma Division
P.O. Box 523, Eindhoven —
the Netherlands*

Single-channel analyser

A new unit in the NIM range of nuclear instrumentation modules produced by Brandenburg Ltd. is the N2031, which combines a fast, high gain amplifier with a single-channel analyser, and is particularly suited to measurements made in conjunction with proportional counters. The equipment is designed to

work with preamplifiers mounted close to the detector, but a charge sensitive front end may be supplied for special applications. The single-channel analyser is preceded by a wide-range amplifier, enabling the module to be used for general pulse-height analysis. System gain is up to 20,000, and the fast response is compatible with proportional counters. Both functions are combined in a single-width NIM module.

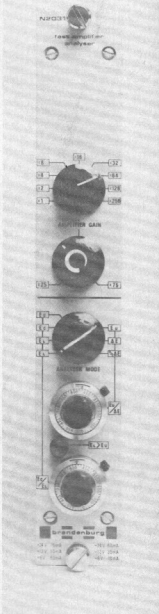

All Brandenburg NIM modules are designed in accordance with AEC specifications, and are fully compatible with CAMAC equipment.

*Brandenburg Limited,
939, London Road,
Thornton Heath,
Surrey. CR4 6 JE. England*



ability to specify a minimum level over a wide temperature range was made possible through a variety of processing and manufacturing improvements. These include improved coupling techniques, use of light reflectors, better isolation materials, and improved LEDs. Designated the MCT210, the new product has a specified minimum CTR of 50 per cent, saturated, and 150 per cent, unsaturated, over a temperature range of 0°C to 70°C. The device incorporates a gallium arsenide diode emitter coupled to a NPN silicon planar phototransistor. The high CTR and low collector-emitter voltage under saturated conditions make the MCT210 excellent for logic load conditions. The saturated output voltage (V_{OL}), collector to emitter, is typically 0.2 volt (specified maximum of 0.4 volt) with a collector current of 16 mA and an input current of 32 mA. The product is identically specified at a forward current of 3.2 mA and a collector current of 1.6 mA.

Isolation voltage between input and output is 4,000 volts, DC, minimum. Isolation resistance is 10^{11} ohms, minimum; isolation capacitance is 1.0 pF, typical. Saturated switching times are typically 2.5 microseconds, rise time, and 25 microseconds, fall time. Propagation delay, high to low, is 2.0 microseconds, typical. Primary applications for the MCT210 are expected to be in logic-to-logic interfaces, particularly in computer and computer peripheral circuits. Other applications areas are line receivers, feedback control circuits, and monitoring circuits.

Monsanto Ltd.
10-18 Victoria St.
LONDON SW1H 0NQ England
(389 M)

Video detector reads laser scans

A new 10-inch video detector especially designed to read laser scans in facsimile machines and automatic measuring equipment for quality assurance and process control applications has been introduced by Sensor Technology.

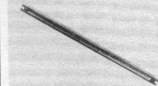

This new 10-inch monodiode provides an extremely economical way to read laser scans in a variety of applications such as pc board quality assurance.

Sensor Technology
21012 Lassen Street
Chatsworth, CA 91311 USA
(394 M)

Multiband comparator

A universal multiband comparator featuring 9-band sorting is available from Electro Scientific Industries.

Able to interface with any instrument with either $3\frac{1}{2}$ or $4\frac{1}{2}$ digit BCD output, the Model SP3971 multiband comparator features a front panel indicator and open collector logic level output for each of 9 contiguous bands. Relay and solenoid outputs are also available. Ideal

breakdown voltage is significantly higher and the drive power loading factor is one-tenth that of the industry standard devices. Low drive requirement means that the new units can drive more peripheral circuits than standard units with an equivalent output power. This results in reduced parts count and simpler circuitry.

Philips Elcoma Division
P.O. Box 523
Eindhoven - the Netherlands
(403 M)

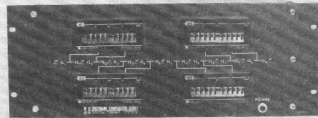

for band sorting of components such as resistors and capacitors. An option permits use with instruments with analog outputs. The several limits can be set asymmetrically about the nominal. Designed with TTL logic; operates at 120 VAC.

Electro Scientific Industries
13900 N.W. Science Park Drive
Portland, Oregon 97229 USA
(390 M)

Low-power MOS-compatible driver ICs

A new series of peripheral driver ICs with one-tenth the input power requirement of competitive units and PNP construction for compatibility with MOS circuits is now available.

Designated DS3611 to DS3614, the new units are rated for 80 V breakdown in the OFF state and a current rating to 300 mA per driver in the ON state. The units feature high voltage PNP inputs compatible with PMOS, CMOS, TTL or DTL circuits. Required input current is just 40 μ A for a logic input (logical '1') of 2.4 V. The new peripheral driver ICs incorporate input clamping diodes for circuit protection. All units are dual drives; DS3611 is AND, DS3612 is NAND, DS3613 is OR and DS3614 is NOR.

The devices are especially well suited for applications with high voltage breakdown, high current requirements as power drivers, relay drivers, lamp drivers, MOS drivers and display drivers in all types of logic-controlled equipment.

The pin-out arrangement for the DS3611-3614 series is identical to industry standard 75451 to 75454 driver ICs. However,

PAL system colour decoder

A new Philips colour decoder, for PAL, the TDA2560/2522/2530 was designed for easy adaptation to TV receivers with remote control facilities. The application of these second-generation integrated circuits reduces the number of peripheral components needed by half and also reduces the number of adjustments from 14 to 7.

The TDA2560 luminance/chrominance control circuit provides linear control within small tolerances over the full range of control voltage by means of a DC controlled electronic potentiometer. A total range of 50 dB between maximum and minimum gain is obtained. The spread in performance avoids separate adjustments for average picture levels with remote control systems.

The TDA2522 colour demodulator circuit is an economic device with good performance. The mean DC level of the output signals is at 5.5 V with a spread of about ± 0.5 V. The mutual spread, however, is only ± 0.2 V, i.e. (R-Y) and (G-Y) output relative to the (B-Y) output. The TDA2530 R.G.B. matrix pre-amplifier provides a very simple video output circuit in conjunction with three pairs of complementary output transistors without compromising on DC stability and h.f. performance. DC controlled electronic potentiometers are used for setting the gains and black levels, since no "hot" potentiometers are employed in the feedback loop, one of the causes of the tendency to oscillate is avoided.

Philips Elcoma Division
P.O. Box 523
Eindhoven - the Netherlands
(396 M)

Interference suppression capacitors

Philips 330-series capacitors provide a low-cost and compact solution to the problems of interference suppression. Main applications will be in small domestic appliances such as mixers, vacuum cleaners and coffee grinders. The capacitors consist of an impregnated low-inductive wound cell of metallised polyethylene-terephthalate (PETP) film and paper film.

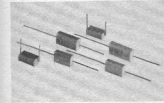

This construction in combination with a flame-retardant polypropylene housing ensures excellent behaviour with respect to active and passive flammability. The 330-series has axial leads which are solder-coated copper wire. One end of the capacitor is provided with stand-off ridges. The rated capacitance range of the new components is from 0.01 to 0.1 μ F, with a rated voltage of 250 V 50 Hz. They are tested to 750 V DC between terminals for 1 minute, and between terminals and coating for 1 minute at 2000 V 50 Hz.

Philips Elcoma Division
P.O. Box 523
Eindhoven - the Netherlands
(395 M)

New optoisolator

Monsanto has announced a new optoisolator product (optical coupler) that offers true TTL compatibility with a specified 1 through 10 unit load saturated output capability over a 0 to 70°C operating temperature range.

The improvement in current transfer ratio (CTR) and the



Stand-up resistors

Philips rectangular wirewound resistors of the 2306 270/273-series are provided with single-ended connections to permit vertical mounting and feature high insulation and non-flammability. They are ideal for high voltage environments such as television receivers.

Designed for high dissipation in small volume, the resistance element is wound in a single layer on a glass-fibre rod which is mounted in a rectangular, sand-filled, ceramic body. Grooves are provided on the sides of the body to accommodate brackets for stable

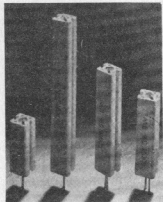

mounting.

The new resistors are available in four power ranges: 7 W, 9 W, 11 W and 17 W rated dissipation at 70°C with resistance values (E12 and E24 series) from 0,12Ω to 18 kΩ. Minimum breakdown voltage of the encapsulation is 2000 V r.m.s.

Philips, Elcoma Division
P.O. Box 523, Eindhoven —
the Netherlands

One second/one minute clock

Intersil, Inc., has introduced the ICM7213, a one second/one minute precision clock and reference generator.

The CMOS circuit is a fully integrated micropower oscillator and frequency divider with four buffered outputs suitable for interfacing with small logic families. The outputs are: one pulse per second, one pulse per minute, 16 Hz, and composite 1024+16+2 Hz. All outputs are TTL compatible.

The circuit's power supply may be either a two battery stack (Ni-cad, alkaline, etc.) or a regular power supply greater than 2 volts. Two volt operation is guaranteed. The circuit features very low power consumption, 100 μA is typical at three volts.

The oscillator feedback resistor is located on-chip. The oscillator requires only 3 external components, fixed capacitor, trim capacitor and a 4.194,304 MHz quartz crystal.

A test speed-up feature provides other frequency outputs including 2048 Hz, 1024 Hz, 34.133 Hz, 16 Hz, 1 Hz and 1/60 Hz. The circuit's inputs are static protected. No special handling is required.

Applications for the ICM7213 include precision timers, frequency references and frequency counter timebases. Devices are packaged in a 14 lead plastic DIP.

Intersil, Incorporated
10900 North Tantau Ave.
Cupertino, CA 95014 USA

(386 M)

Bias-light Plumbicon

Amperex Electronic Corporation has announced a new family of Plumbicon TV pickup tubes for broadcast applications.

Designated the XQ1410, the new tubes feature internal bias lighting that significantly reduces both rise time and signal decay lag, essentially eliminating color fringing and picture smear in low-key lighting conditions.

According to Amperex, the new tubes are expected to become an important factor in color telecasting.

The bias light principle is well established in pickup tube technology, but has not yet been adequately exploited in broadcast TV.

The bias light impinges on the rear surface of the target and causes a few nanoamperes of dark current to flow in the tube, modifying its beam acceptance characteristics. Since signal rise time and decay lag are critically related to beam acceptance, the net effect is a sharp improvement in both.

The XQ1410 is designed to accept external electronic control of the amount of bias light introduced on the target. This permits adjustment of dark current over an operating range that minimizes rise time and decay lag in the particular application. Since there are specific XQ1410's for all three color channels and for luminance, the ability to control bias light

allows all channels to be adjusted to produce the same (extremely small) lag. With nearly identical lag in all three channels, overall camera performance is vastly improved, especially in low-key lighting circumstances.

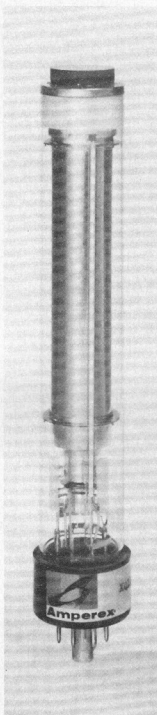

The XQ1410 is physically and electrically interchangeable with the widely-used XQ1020 series of broadcast Plumbicon tubes, with only a minor field change being required for adjustment of bias light.

However, the XQ1410 may also be used with fixed-bias light simply by omitting the control circuit, in which case no field modification is required.

Amperex Electronic Corporation,
Slatersville Division, Slatersville,
Rhode Island 02876. USA

Wide-band internally compensated op-amp

Optical Electronics, Inc., is now in production, and has available from stock, the Model 9916 bipolar input operational amplifier. The 9916 features 200 MHz unity gain frequency with internal compensation providing a smooth, well behaved, 6 dB/octave roll-off rate of the open loop gain.

+ 300 volts/μsecond slewing rate allows the 9916 to handle video signals and the internal compensation makes the 9916 useful for high fidelity pulse amplification, wide band logarithmic amplifiers,

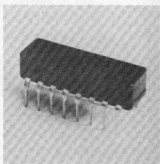

high speed integrators, fast differentiators, video amplifiers and gamma correction circuits. Low input noise makes the 9916 useful in ultrasonic detection systems, vidicon and photo array preamplifiers and fast charge amplifier applications.

Optical Electronics, Inc.
P.O. Box 11140
Tucson, Arizona 85734 USA

(391 M)

Low-consumption op-amp

Philips TDA4250 is a versatile, programmable monolithic operational amplifier specially designed for applications requiring low stand-by power consumption over a wide range of supply voltages such as battery powered equipment.

The quiescent current of the amplifier can be set by a single external resistor or current source. With this programming, the power consumption, input current, slew rate and gain-bandwidth product can be tailored to a particular application. The current consumption can be reduced to a few microamps.

The TDA4250 requires no frequency compensation, is fully protected against short circuits, and operates with a supply voltage from ± 1 V to ± 18 V. The operating temperature range is -25°C to +85°C.

Two versions of the TDA4250 are available: the TDA4250B in a 8-pin dual in-line package, and TDA4250D in the new 8-pin SO miniature package which is ideal for hybrid circuits.

Philips Elcoma Division
P.O. Box 523,
Eindhoven — the Netherlands

(397 M)



voltage of 4 kV is 380 mA when operating with a matched load at 2,450 GHz. The YJ1500 magnetron is designed to be run from an LC stabilized half-wave doubler anode supply, and may be mounted in any position. The rate of flow of the cooling air required is 1 m³ per minute.

Philips Elcoma Division
P.O. Box 523
Eindhoven - the Netherlands

(387 M)

Frequency counter timebase

Intersil has broadened its line of timing microcircuits through the addition of the ICM7207A, a new frequency counter timebase. Used together with a 5.24288 MHz crystal and a 7 digit unit counter such as Intersil's ICM7208, the new circuit becomes a complete timer-frequency counter.

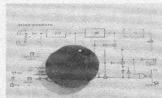

The new circuit is pin-for-pin compatible with Intersil's ICM7207, however it has 0.1 and 1 second count enable window output.

When used with the ICM7208 the circuit's four outputs provide the gating signals for the count window, store function, reset function and multiplex frequency reference. The 1 second count

enable makes it possible to obtain 7 significant digits when measuring frequencies over 1 MHz with the least significant digit reading in Hz.

The ICM7207A will take crystals from 1 to 10 MHz, providing outputs at crystal frequency, and at $\pm 2^3$, $\pm 2^5$ or $\pm (2^3 \times 10)$ divider stages.

The new circuit has a stable HF oscillator.

It dissipates less than 5 mW at 5 volts.

According to Intersil, the new circuit will be quite useful for applications requiring a system timebase, oscilloscope calibration generator, marker generator strobe, or frequency counter controller.

The circuit is packaged in a 14 pin DIP.

Intersil, Incorporated
10900 North Tantau Ave.
Cupertino, CA 95014 USA

(385 M)

Voltage and current calibrator

A new AC and DC voltage and current calibrator has been announced by RFL Industries, Inc. The Model 82 features full-scale AC and DC voltage ranges of 100 mV, 1 volt and 10 volts. Full-scale alternating and direct current ranges of 100 μ A,

1 mA, 10 mA and 100 mA are incorporated into the all solid-state instrument. Nominal accuracies of 0.01% DC and 0.05% AC enable the Model 82 to test a wide range of analog and digital meters. The four amplitude setting dials provide a resolution of 0.01% of full scale and a "percent deviation" dial, ranged at $\pm 0.3\%$ and $\pm 3\%$, enables precise resolution of 0.01% of reading.

A "scale division" function allows analog meters to be quickly and accurately calibrated at scale division factors of 8, 10, 12 and 15. A Run-Up position is also included to enable analog meters to be checked for stickiness and digital meters for lock-up.

An internal oscillator provides AC calibrations from 40 Hz to 1 kHz with continuous frequency settability. Calibrations may be performed to 25 kHz using an external oscillator. Overload protection is provided for all ranges and functions of the Model 82. The instrument is suitable for either bench or rack mount use and has dimensions of 17.8 cm high by 48.3 cm wide by 36.8 cm deep. Weight is 8.2 kg and operation is from either 115 or 230 volt, 50/60 Hz line.

RFL Industries, Inc.
Boonton,
New Jersey 07005 USA

(388 M)

1 kW cooker magnetron

Philips new YJ1500 continuous wave magnetron has been specially designed for use in domestic microwave cookers where low-cost and reliability count. Featuring packaged, metal-ceramic construction, the YJ1500 magnetron is designed for cold starting with a quick-heating thoriated tungsten cathode. The tube incorporates an integral r.f. cathode filter, and is forced air-cooled.

Power output of the YJ1500 magnetron under typical operating conditions is 1100 W when the efficiency is 72%. Mean anode current with a peak anode

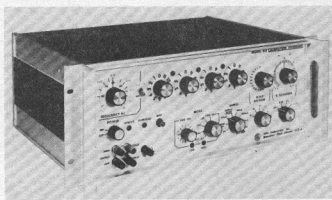
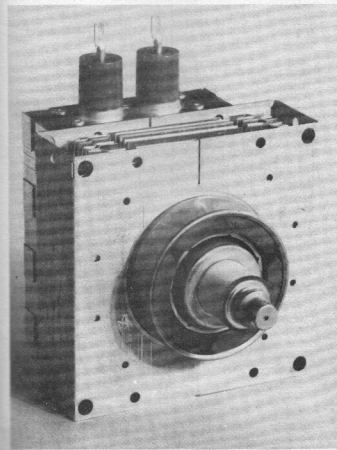

advertisers index

Anco	page 3-62
Arrow	page 3-10
Babani	page 3-10
B. Bamber	page 3-61
Bi-Pak	page 3-60
Brinck	page 3-64
Candis	page 3-62
Cliffpalm	page 3-62
Decon	page 3-67
Electrovalue	page 3-57
Elektor	page 3-08/3-64/3-65/3-66
Elektron enterprises	page 3-59
F.G. electronics	page 3-09
Greenbank	page 3-64
Hybrid	page 3-57
H.B. electronics	page 3-02/3-03
I.L.P.	page 3-58
Maplin	page 3-68
Phoenix	page 3-11
Swanley	page 3-08
Technomatic	page 3-61
Vero	page 3-08/3-09



Modifications to
Additions to
Improvements on
Corrections in
Circuits published in Elektor

IC audio

January 1977, E 21, p. 1-42. As mentioned in the article, the TDA2020 may be used with either a symmetrical power supply or with a single power supply rail. A printed circuit board was originally designed and tested for both versions. For practical reasons, the latter option was preferred and its circuit was shown in figure 5.

Inexplicably, the board layout shown in figure 6 is for the symmetrical supply version however. To straighten things out, the correct p.c. board and component layout for the single supply version are shown here; also, the circuit for the symmetrical supply version is shown in figure 2. Note that this is *not* the preferred version, but it does work provided care is taken to ensure that the supply rails always switch on and off together, even under fault conditions. Furthermore, we have just received an updated version of the SGS data sheet

and this shows a few minor modifications to the circuits:

- two clamping diodes are included across the output of the IC as shown in figure 3. (a for the symmetrical supply version shown here and b for the single supply version shown in the original article)
- the roll-off capacitor C4 is now connected between pins 9 and 14 instead of between pins 9 and 10
- for the single supply version (original article, figure 5) "it is not recommended to load this circuit with less than 8 Ω , since the phase shift caused by the capacitor could then cause damage to the IC".

We give these tips here for what they are worth; use of clamping diodes is standard practice, of course.

Piano tuner

July/August 1976, E 15/16, p. 742. The diode joining row 7 and column B of the matrix should be removed, as otherwise the B will be slightly flat.

Sensitive metal detector

November 1976, E 19, p. 1116. In the parts list, C20 is shown as 33 p. This should, of course, be 100 n as shown in the circuit diagram.

FM on 11 meters

October 1976, E 18, p. 1013. In figure 4, T2 and T3 are shown as BF245; this should be BF254.

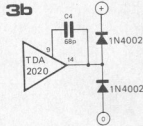
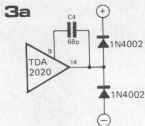
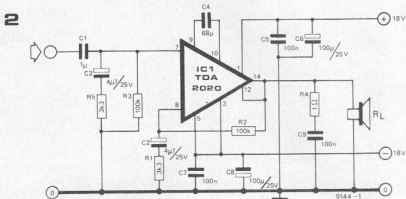

9144L

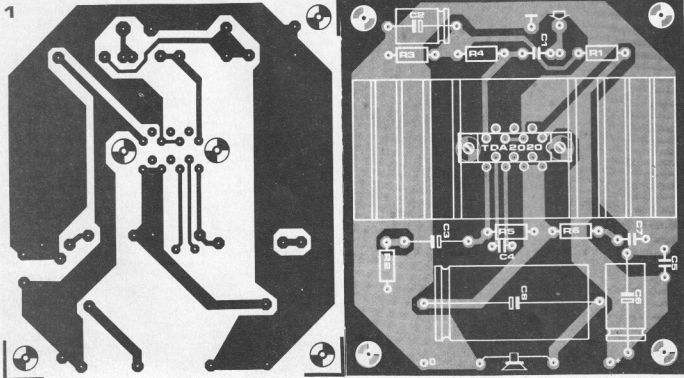

The circuit consists of a high impedance input buffer, a low leakage electronic switch, switch driver circuit, and a junction FET output amplifier. Applications include 12-bit data acquisition systems, DAC deglitching circuits, automatic zeroing circuits, and analog demultiplexing circuits. Price, SHM-LM-2 (1-9): \$ 7.95. DATEL Systems, Inc. 1020 Turnpike St., Canton, Mass. 02021 USA

(392 M)

Slide potentiometers

The new slide potentiometers, type 415 from Philips are designed for use in domestic appliances and small portable radios. They have been developed for pcb preset resistance control with provision for re-adjustment and are provided with a knob. Two types of knobs are available. The maximum slider travel is only 25 mm.

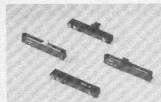

The 415 series is available with nominal resistance values of 1 k Ω to 4.7 M Ω with a linear resistance law, and 1 k Ω to 2.2 M Ω with a logarithmic law, providing maximum attenuation from 30 to 70 dB and 40 to 80 dB, respectively.

The potentiometers have a straight carbon track fitted to a base plate of resin-bonded paper, which is mounted inside a black synthetic resin housing. The terminals are suitable for mounting on printed wiring boards by dip-soldering.

Philips Elcoma Division
P.O. Box 523

Eindhoven - the Netherlands

(393 M)

Monolithic sample-hold

Model SHM-LM-2 is a new, low cost sample-hold circuit fabricated with monolithic technology. Its performance features make it an excellent choice for use with 12-bit A/D converters. This device is self-contained, requiring only a user-selected external holding capacitor and 25 μ sec using a 1000 pF capacitor and 25 μ sec using a 0.01 μ F capacitor. For a 10 V change to 0.1%, acquisition time is 5 μ sec and 20 μ sec respectively. Other important specifications include an aperture time of 100 nsec, a bandwidth of 1 MHz, and an input impedance of 10¹⁰ ohms. Hold mode feed-through is less than 0.005%. Hold mode droop is 200 μ V/msec maximum with a 1000 pF hold capacitor and 20 μ V/msec maximum with a 0.01 μ F hold capacitor. The SHM-LM-2 operates over a power supply range of ± 5 V to ± 18 V and

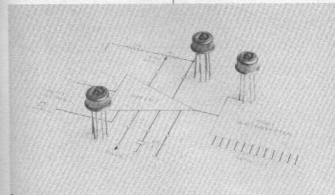

draws a quiescent current of 6 mA. The package is a hermetically-sealed TO-99 metal can. The sample control terminal can be programmed to accept different logic types (TTL, CMOS, etc.) and will operate from both inverted and non-inverted sample pulses.

ELECTROVALUE

SEMI-CONDUCTORS (OPTO, IC'S, etc.) COMPONENTS, TOOLS, etc.

Catalogue No. 8

3rd. printing-up dated

More than ever to choose from

With updated price information we also include new items in our third printing of Catalogue 8, metres in particular forming a valuable new feature. The 144-page catalogue is still only 40p post paid together with voucher worth 40p for spending on orders over \pounds 5. net. No reader should be without the Electro value Catalogue - We still pay postage on all C.W.O. orders in U.K. min. value \pounds 2.00 AND GIVE GENUINE DISCOUNTS ON PRICES TOO!

Service Quality Discounts

ELECTROVALUE LTD

All communications to Section 1/3, 28, ST. JUDES ROAD, ENGLEFIELD GREEN, EGHAM, SURREY TW20 0HB

Telephone Egham 3603, Telex 2644475

NORTHERN BRANCH: 680, Burnage Lane, Manchester M 19 1 NA

Telephone (0611) 432 4945

Shop hours: both addresses: Daily 9.5.30pm: 9-1pm Sats.

HYBRID for transformers

MINIATURE AND SUB MINIATURE RANGE

Volts	Amps	Ref. No.	Prices £
3-0.3	0.2	238	2.50
0.6-0.6	1.1	212	2.97
9-0.9	0.1	13	2.28
0.9-0.9	0.33-0.33	235	2.39
0.9-0.9-9	0.5, 0.5	207	3.14
0.8-0.9-9	1.1	208	4.51
0.15-0.15	0.2-0.2	236	2.28
0.2-0.2-0	0.3-0.3	214	3.22
0.15-20.0-15-20.1	1.1	206	5.37
0.15-27.0-15-27.0	5.0, 5.0	203	4.77
0.15-27.0-15-27.1	1.1	204	6.00

50 VOLT RANGE

Primary 220-240 V		
Secondary 0-25-33-40-50 V		
Amps	Ref. No.	Price £
0.5	102	4.07
1	103	5.27
2	104	7.17
3	105	8.77
4	106	11.26
6	107	17.29
8	118	18.62

60 VOLT RANGE

Primary 220-240 V		
Secondary 0-30-40-48-60 V		
Amps	Ref. No.	Price £
0.5	124	3.94
1	126	5.43
2	127	7.65
3	125	11.00
4	123	13.07
5	40	14.20
6	120	16.64

AUTO TRANSFORMERS

V(A)	Taps	Ref. No.	Price £
20	0-115-210-240	113	2.81
75	0-115-210-240	64	4.85
150	0-115-200-220-240	4	6.24
300	0-115-200-220-240	66	8.62
600	0-115-200-220-240	67	13.10
1000	0-115-200-220-240	84	19.70

30 VOLT RANGE

Primary 220-240 V		
Secondary 0-12-15-20-24-30 V		
Amps	Ref. No.	Prices £
0.5	112	3.15
1.0	79	4.00
2	2	5.55
3	20	6.97
4	21	7.93
5	51	9.55
6	117	10.69
8	88	14.15
10	89	14.51

MAINS ISOLATING TRANSFORMERS

Primary 105/120 or 200/240 V		
Secondary 105/120 C.T. or 200/240 V.C.T.		
VA (Watts)	Ref. No.	Prices £
50	149	6.68
100	150	7.65
200	151	11.95
250	152	14.47
350	153	17.14
500	154	19.73

Prices are inclusive of VAT and Post & Packing. Access and Barclaycard facilities are available.

Hybrid Electronics Ltd, Crossland House, Nackington, Canterbury, Kent. CT4 7AD Telephone: (02271) 64723 Telex: 965780

The new Maplin Catalogue is no ordinary catalogue...

Hundreds of fascinating new lines.

Several major new projects to build.

MAPLIN ELECTRONIC SUPPLIES



SUPERSONIC SAME DAY SERVICE!

QUALITY COMPONENTS PART 1!

Simple Voltage Source you can build!

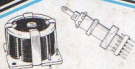

Component section includes a wide range of coils, pot cores, ready-wound coils and chokes from microhenries to Henries, plus ranges of Denco coils and i.f. transformers etc.

Hundreds of photographs and illustrations.

The new tools section includes a range of soldering irons and equipment whilst the test gear section includes a selection of multimeters from 1000 V to 100,000 V to suit your requirements.

Find out about our major electronics projects you can build. Our catalogue will help you choose one of our many leaflets and books giving full instructions details of such exciting projects as a stereo graphic equaliser, or an electronic organ, an advanced electronic organ, our advanced synthesizers - and many more.

Catalogue includes a very wide range of components: hundreds of different capacitors; resistors; transistors; I.C.'s; diodes; wires and cables; discotheque equipment; organ components; musical effects units; microphones; turntables; cartridges; styli; test equipment; boxes and instrument cases; knobs, plugs and sockets; audio leads; switches; loudspeakers; books; tools - AND MANY MANY MORE.

SEND THIS COUPON FOR **YOUR COPY OF OUR CATALOGUE ON APPROVAL!** Price 50p - SEND NO MONEY NOW. Please rush me a copy of your brand new 1977/78 catalogue by return of post. Only if I am completely satisfied that it is worth every penny, will I send 50p within 14 days of receipt. If I am not satisfied, I may return the catalogue to you within 14 days without obligation. I understand that I need not purchase anything from your catalogue should I choose to keep it.

NAME _____

ADDRESS _____

Maplin Electronic Supplies P.O. Box 3, Rayleigh, Essex, SS6 8LR

DON'T DELAY POST COUPON NOW IT COULD BE THE BEST 50p YOU'VE EVER SPENT.

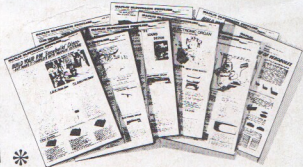

* Our bi-monthly newsletter keeps you up to date with latest guaranteed prices - our latest special offers (they save you pounds) - details of new projects and new lines. Send 30p for the next six issues (5p discount voucher with each copy).

MAPLIN

ELECTRONIC SUPPLIES P.O. BOX 3, RAYLEIGH, ESSEX SS6 8LR

Telephone: Southend (0702) 715155
Call at our shop: 284 London Road, Westcliff-on-Sea, Essex. (Closed all day Monday) Telephone: Southend (0702) 47379